

---

# Sycon Instruments

## STM-100 / MF

### Thickness / Rate Monitor

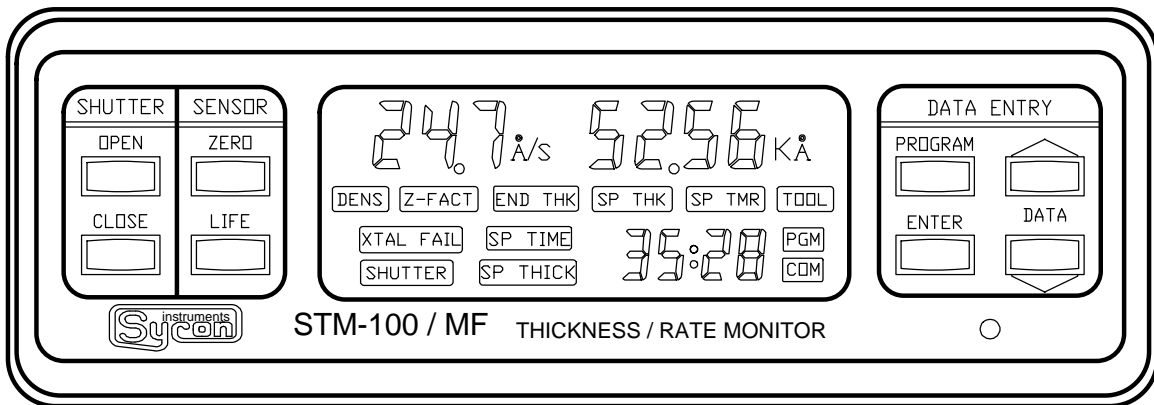

Users Manual

---

September 1997 Rev. G

## Preface

Sycon Instruments, Inc. reserves the right to change any information contained in this manual without notice.

© Copyright Sycon Instruments, Inc. 1989-1993

|                   |   |
|-------------------|---|
| <b>IBM®</b>       | is a Registered trademark of I B M Corporation              |
| <b>MICROSOFT®</b> | is a Registered trademark of Microsoft Corporation          |
| <b>SWAGELOK®</b>  | is a Registered trademark owned by Crawford Fitting Company |
| <b>BITBUS™</b>    | is a trademark of Intel Corporation                         |
| <b>CONFLAT®</b>   | is a Registered trademark of Varian Associates, Inc.        |
| <b>AMPHENOL®</b>  | is a Registered trademark of Allied Corporation             |

## Warranty

### SYCON INSTRUMENTS, INC.

#### Policy

Sycon Instruments, Inc. (Sycon) warrants that all electronic instrumentation equipment manufactured by Sycon shall be free from defects in materials and workmanship for a period of 2 years from date of shipment. Mechanical vacuum components such as feedthroughs, sensors, cables, and shutters shall be warranted for a period of six months from the date of shipment. For the duration of the warranty period Sycon will, at its option, either repair or replace any part which is defective in materials or workmanship without charge to the purchaser. The foregoing shall constitute the exclusive and sole remedy of the purchaser for any breach by Sycon of this warranty.

This warranty does not apply to any equipment which has not been used in accordance with the specifications recommended by Sycon for the proper and normal use of the equipment. Sycon shall not be liable under any circumstances for consequential or incidental damages in connection with, or arising out of the sale, performance, or use of, the equipment covered by this warranty.

This warranty is in lieu of all other warranties by Sycon, expressed or implied, including the implied warranty of merchantability, the implied warranty of fitness for a particular purpose, and warranty against infringement of any patent.

#### EQUIPMENT RETURN

Before returning any equipment to Sycon contact the Product Service Department in your area for instructions. Obtain a **RA** (Return Authorization) number and indicate this number on all shipping cartons and correspondence. Ship all items in suitable containers with adequate protection from outside damage.

Sycon Instruments, Inc.  
6757 Kinne Street  
East Syracuse, New York  
13057-1215  
Phone (315) 463-5297  
Fax (315) 463-5298

## EC Declaration of Conformity

We,  
SYCON Instruments  
6757 Kinne Street  
East Syracuse, NY 13057  
USA

declare under sole responsibility that the

### **STM-100/MF Thickness/Rate Monitor**

meets the intent of Directive 89/336/EEC as amended by 92/31/EEC and 93/68/EEC for Electromagnetic Compatibility and the 72/23/EEC Low Voltage Directive for Product Safety. Compliance was demonstrated to the following specifications as listed in the Official Journal of the European Communities:

EN 50081-1: 1992 Emissions

EN 50022                      Class B Radiated and Conducted Emissions

EN 61000-3-2    AC Power Line Harmonic Current Emissions

EN 50082-1: 1995 Immunity

IEC 1000-4-2    Electrostatic Discharge Immunity

IEC 1000-4-3    RF Electromagnetic Field Immunity

IEC 1000-4-4    Electrical Fast Transient/Burst Immunity

IEC 1000-4-5    Power Line Surge Immunity

IEC 1000-4-11   Power Line Dips and Interrupts Immunity

EN 61010-1: 1993 Safety Requirements for Electrical Equipment for Measurement, Control, and Laboratory Use

# Table of Contents

|  |            |
|--|------------|
| <b>PREFACE</b> .....                         | I          |
| <b>WARRANTY</b> .....                        | II         |
| SYCON INSTRUMENTS, INC. POLICY.....          | II         |
| EQUIPMENT RETURN.....                        | II         |
| <b>TABLE OF CONTENTS</b> .....               | IV         |
| <b>LIST OF FIGURES</b> .....                 | VIII       |
| <b>LIST OF TABLES</b> .....                  | IX         |
| <b>GENERAL INFORMATION</b> .....             | <b>1-1</b> |
| INTRODUCTION.....                            | 1-1        |
| SECTION 1.1.....                             | 1-1        |
| UNPACKING.....                               | 1-1        |
| SECTION 1.2.....                             | 1-1        |
| STM-100 / MF SPECIFICATIONS.....             | 1-2        |
| SECTION 1.3.....                             | 1-2        |
| SENSOR SPECIFICATIONS.....                   | 1-4        |
| SECTION 1.4.....                             | 1-4        |
| OPERATION.....                               | 1-4        |
| FEEDTHROUGH INSTALLATION.....                | 1-4        |
| WATER.....                                   | 1-4        |
| ELECTRICAL.....                              | 1-4        |
| MATERIALS (IN VAC).....                      | 1-4        |
| SENSOR SPARE PARTS.....                      | 1-5        |
| SECTION 1.5.....                             | 1-5        |
| STM-100 / MF PARTS & ACCESSORIES.....        | 1-5        |
| SECTION 1.6.....                             | 1-5        |
| MONITOR.....                                 | 1-5        |
| FEEDTHROUGHS.....                            | 1-5        |
| SENSORS.....                                 | 1-5        |
| OPTIONS.....                                 | 1-5        |
| ACCESSORIES.....                             | 1-5        |
| SENSOR CRYSTALS.....                         | 1-5        |
| <b>OPERATION AND PROGRAMMING</b> .....       | <b>2-1</b> |
| KEYBOARD DESCRIPTION.....                    | 2-1        |
| SECTION 2.1.....                             | 2-1        |
| SYSTEM CONTROL KEY GROUP.....                | 2-1        |
| SECTION 2.2.....                             | 2-1        |
| SHUTTER KEYS.....                            | 2-1        |
| ZERO KEY.....                                | 2-2        |
| CRYSTAL LIFE KEY.....                        | 2-2        |
| DATA ENTRY AND PROGRAMMING GROUP.....        | 2-2        |
| SECTION 2.3.....                             | 2-2        |
| PROGRAM KEY.....                             | 2-3        |
| ENTER KEY.....                               | 2-3        |
| ARROW KEYS.....                              | 2-3        |
| FILM PARAMETERS.....                         | 2-4        |
| SECTION 2.4.....                             | 2-4        |
| LCD DATA DISPLAYS.....                       | 2-4        |
| FILM NUMBER PARAMETER.....                   | 2-4        |
| DENSITY PARAMETER.....                       | 2-5        |
| Z-FACTOR PARAMETER.....                      | 2-6        |
| END THICKNESS.....                           | 2-6        |
| SETPOINT THICKNESS PARAMETER.....            | 2-7        |
| SETPOINT TIMER.....                          | 2-8        |
| TOOLING FACTOR PARAMETER.....                | 2-8        |
| USER CONFIGURATION SWITCHES.....             | 2-9        |
| SECTION 2.5.....                             | 2-9        |
| SWITCH FUNCTION DEFINITIONS.....             | 2-9        |
| CONFIGURATION.....                           | 2-9        |
| TEST MODE.....                               | 2-12       |
| SECTION 2.6.....                             | 2-12       |
| ENABLING THE TEST MODE.....                  | 2-12       |
| BEEPER.....                                  | 2-12       |
| SECTION 2.7.....                             | 2-12       |
| DISABLING THE BEEPER.....                    | 2-12       |
| <b>INSTALLATION</b> .....                    | <b>3-1</b> |
| ELECTRICAL CONNECTIONS AND DESCRIPTIONS..... | 3-1        |
| SECTION 3.1.....                             | 3-1        |
| SECTION 3.2.....                             | 3-1        |
| LINE POWER WARNING.....                      | 3-1        |

|  |            |
|--|------------|
| LINE VOLTAGES .....                          | 3-1        |
| GROUND .....                                 | 3-2        |
| SECTION 3.3.....                             | 3-2        |
| GROUNDING.....                               | 3-2        |
| CONNECTOR SHIELDING.....                     | 3-2        |
| I/O INTERFACE CONNECTION .....               | 3-3        |
| SECTION 3.4.....                             | 3-3        |
| I/O CONNECTOR .....                          | 3-3        |
| RELAYS.....                                  | 3-3        |
| INPUTS.....                                  | 3-3        |
| RELAY OUTPUTS .....                          | 3-3        |
| RELAY OUTPUTS .....                          | 3-3        |
| CRYSTAL FAIL .....                           | 3-3        |
| ELAPSED TIMER .....                          | 3-3        |
| SHUTTER.....                                 | 3-4        |
| THICKNESS SETPOINT.....                      | 3-4        |
| REMOTE INPUTS.....                           | 3-4        |
| REMOTE INPUTS.....                           | 3-4        |
| SHUTTER RELAYS.....                          | 3-4        |
| THICKNESS ZERO INPUT.....                    | 3-4        |
| TIMER ZERO INPUT .....                       | 3-4        |
| REMOTE INPUT SPECIFICATIONS .....            | 3-4        |
| SENSOR CONNECTION .....                      | 3-5        |
| SECTION 3.5.....                             | 3-5        |
| OSCILLATOR CONNECTION.....                   | 3-5        |
| ANALOG RECORDER INTERFACE .....              | 3-5        |
| SECTION 3.6.....                             | 3-5        |
| ANALOG OUTPUT SPECIFICATIONS .....           | 3-5        |
| RECORDER CALIBRATION .....                   | 3-6        |
| RECORDER OUTPUTS.....                        | 3-6        |
| RS-232 SERIAL COMMUNICATIONS INTERFACE ..... | 3-7        |
| SECTION 3.7.....                             | 3-7        |
| RS-232 CONNECTIONS .....                     | 3-7        |
| RS-232 CONNECTOR DEFINITIONS .....           | 3-7        |
| COMMUNICATIONS OPTIONS.....                  | 3-8        |
| SECTION 3.8.....                             | 3-8        |
| COMMUNICATIONS OPTIONS.....                  | 3-8        |
| DEPOSITION SYSTEM INSTALLATION .....         | 3-8        |
| SECTION 3.9.....                             | 3-8        |
| SYSTEM INSTALLATION .....                    | 3-8        |
| SENSOR INSTALLATION .....                    | 3-9        |
| INSTALLING WATER LINES .....                 | 3-9        |
| WATER LINES.....                             | 3-9        |
| VACUUM FEEDTHROUGH .....                     | 3-10       |
| VACUUM FEEDTHROUGH .....                     | 3-10       |
| ELECTRICAL IN-VACUUM CABLE .....             | 3-11       |
| VACUUM ELECTRICAL CONNECTIONS .....          | 3-11       |
| BAKEABLE SENSOR.....                         | 3-11       |
| <b>CALIBRATION AND THEORY .....</b>          | <b>4-1</b> |
| MEASUREMENT THEORY .....                     | 4-1        |
| SECTION 4.1.....                             | 4-1        |
| EQUATION 1:.....                             | 4-1        |
| MEASURING PERIOD .....                       | 4-1        |
| RATE COMPUTATION .....                       | 4-1        |
| THICKNESS READING CALIBRATION .....          | 4-2        |
| SECTION 4.2.....                             | 4-2        |
| THICKNESS .....                              | 4-2        |
| DENSITY DETERMINATION.....                   | 4-2        |
| DENSITY.....                                 | 4-2        |
| Z-FACTOR DETERMINATION.....                  | 4-2        |
| Z-FACTOR.....                                | 4-2        |
| TOOLING DETERMINATION .....                  | 4-3        |
| SECTION 4.3.....                             | 4-4        |
| MATERIAL REFERENCE TABLE.....                | 4-4        |
| BULK DENSITY AND Z-FACTOR VALUES .....       | 4-4        |
| ALUMINUM THROUGH INDIUM .....                | 4-4        |
| INDIUM INTIMONIDE THROUGH TANTALUM.....      | 4-5        |
| TELURIUM THROUGH ZIRCONIUM OXIDE .....       | 4-6        |
| <b>COMPUTER INTERFACING.....</b>             | <b>5-1</b> |
| RS-232 INTERFACE.....                        | 5-1        |
| SECTION 5.1.....                             | 5-1        |
| RS-232 DESCRIPTION.....                      | 5-1        |
| BAUD RATES AND CABLING.....                  | 5-1        |

|  |            |
|--|------------|
| MAKING AN RS-232 CABLE .....                         | 5-2        |
| COMMUNICATION DEMO DISK.....                         | 5-2        |
| SETTING BAUD RATES.....                              | 5-2        |
| SYCON PROTOCOL.....                                  | 5-3        |
| SECTION 5.2.....                                     | 5-3        |
| MESSAGE FORMAT .....                                 | 5-3        |
| BASIC DRIVER ROUTINE.....                            | 5-4        |
| SECS-II PROTOCOL.....                                | 5-5        |
| SECTION 5.3.....                                     | 5-5        |
| SECS-II ADDRESSING .....                             | 5-5        |
| SECS-II PROTOCOL .....                               | 5-5        |
| DOCUMENTATION REQUIREMENTS .....                     | 5-5        |
| GENERAL INFORMATION .....                            | 5-5        |
| MESSAGE SUMMARY.....                                 | 5-6        |
| SECS-II MESSAGES .....                               | 5-6        |
| MESSAGE DETAILS .....                                | 5-6        |
| IEEE-488 INTERFACE OPTION.....                       | 5-7        |
| SECTION 5.4.....                                     | 5-7        |
| COMMANDS.....  | 5-7        |
| SECTION 5.5.....                                     | 5-7        |
| RESPONSE FORMAT .....                                | 5-7        |
| COMMAND LIST FOR STM-100 / MF .....                  | 5-8        |
| DETAILED COMMAND DESCRIPTION.....                    | 5-9        |
| SECTION 5.6.....                                     | 5-9        |
| SOFTWARE VERSION CODE .....                          | 5-9        |
| SHUTTER RELAY CONTROL.....                           | 5-9        |
| ZERO THICKNESS AND TIMER .....                       | 5-9        |
| ZERO THICKNESS .....                                 | 5-9        |
| ZERO TIMER .....                                     | 5-9        |
| SET THE DENSITY PARAMETER .....                      | 5-9        |
| SET THE Z-FACTOR PARAMETER .....                     | 5-9        |
| SET THE END THICKNESS.....                           | 5-9        |
| SET THE SETPOINT RELAY THICKNESS .....               | 5-10       |
| SET THE TIMER RELAY PARAMETER.....                   | 5-10       |
| SET THE TOOLING FACTOR PARAMETER .....               | 5-10       |
| TURN THE TEST MODE ON/OFF .....                      | 5-10       |
| ACKNOWLEDGE THE STATUS OF NON-VOLITILE MEMORY.....   | 5-10       |
| GET THE CRYSTAL FAIL STATUS .....                    | 5-10       |
| GET THE STATUS OF THE SETPOINT TIMER RELAY.....      | 5-10       |
| GET THE STATUS OF THE SETPOINT THICKNESS RELAY ..... | 5-10       |
| GET THE STATUS OF THE END THICKNESS RELAY .....      | 5-11       |
| GET THE REMOTE INPUT STATUS .....                    | 5-11       |
| GET THE CONFIGURATION SWITCH STATUS .....            | 5-11       |
| GET THE THICKNESS VALUE.....                         | 5-11       |
| GET THE RATE VALUE .....                             | 5-11       |
| GET THE SENSOR FREQUENCY.....                        | 5-11       |
| GET THE CRYSTAL LIFE VALUE.....                      | 5-12       |
| GET THE TIMER VALUE .....                            | 5-12       |
| GET THE SHUTTER CLOSE EVENT THICKNESS LOG .....      | 5-12       |
| GET THE SHUTTER CLOSE TIME LOG.....                  | 5-12       |
| GET THE LOG EVENT RATE .....                         | 5-12       |
| GET THE POWER ON STATUS .....                        | 5-12       |
| FORCE PARAMETERS TO THEIR DEFAULT VALUES.....        | 5-13       |
| TURN THE KEY BOARD BEEPER ON/OFF .....               | 5-13       |
| INTERNAL USE COMMANDS.....                           | 5-13       |
| MULTI-FILM FILM NUMBER SELECTION .....               | 5-13       |
| MULTI-FILM DENSITY PARAMETER.....                    | 5-14       |
| MULTI-FILM Z-FACTOR PARAMETER.....                   | 5-14       |
| MULTI-FILM END THICKNESS PARAMETER.....              | 5-14       |
| MULTI-FILM SET POINT RELAY THICKNESS PARAMETER.....  | 5-14       |
| MULTI-FILM SET POINT TIMER RELAY PARAMETER .....     | 5-14       |
| MULTI-FILM TOOLING FACTOR PARAMETER.....             | 5-14       |
| <b>MAINTENANCE .....</b>                             | <b>6-1</b> |
| WARNINGS.....  | 6-1        |
| SECTION 6.1.....                                     | 6-1        |
| CONTROL UNIT .....                                   | 6-1        |
| REPLACING A SENSOR CRYSTAL.....                      | 6-2        |
| SECTION 6.2.....                                     | 6-2        |
| PERSISTENT CRYSTAL FAIL INDICATION .....             | 6-3        |
| SECTION 6.3.....                                     | 6-3        |
| <b>COMMUNICATION DEMO DISK.....</b>                  | <b>0-1</b> |
| SECTION A-1 .....                                    | 0-1        |
| STM-100 /MF SPECIFIC PROGRAMS.....                   | 0-2        |

|                               |            |
|-------------------------------|------------|
| SECTION A-2 .....             | 0-2        |
| <b>SHMX-4 OPERATION .....</b> | <b>0-1</b> |
| INTRODUCTION .....            | 0-1        |
| OPERATION .....               | 0-2        |
| INSTALLATION .....            | 0-2        |



## List of Figures

|  |     |
|--|-----|
| Figure 1.1: Standard Sensors. ....                                       | 1-4 |
| Figure 2.1: STM-100 / MF Front Panel.....                                | 2-1 |
| Figure 2.2: System Control Keys.....                                     | 2-1 |
| Figure 2.3: Data Entry And Programming Keys. ....                        | 2-2 |
| Figure 2.4: LCD Data Areas. ....   | 2-4 |
| Figure 2.5: LCD Variable Parameter Legends. ....                         | 2-4 |
| Figure 2.6: Film Number Parameter.....                                   | 2-5 |
| Figure 2.7: Density Parameter. ....                                      | 2-5 |
| Figure 2.8: Z-Factor Parameter.....                                      | 2-6 |
| Figure 2.9: End Thickness Parameter.....                                 | 2-6 |
| Figure 2.10: Set Point Thickness Parameter.....                          | 2-7 |
| Figure 2.11: Set Point Timer Parameter.....                              | 2-7 |
| Figure 2.12: Tooling Parameter.....                                      | 2-8 |
| Figure 2.13: Configuration Switch Settings. ....                         | 2-9 |
| Figure 3.1: Rear Panel. ....   | 3-1 |
| Figure 3.2: Recommended Grounding Procedure. ....                        | 3-2 |
| Figure 3.3: Recorder Output Plug. ....                                   | 3-5 |
| Figure 3.4: Example of Thickness Mode Recorder Output.....               | 3-6 |
| Figure 3.5: Example of Rate Mode Recorder Output. ....                   | 3-6 |
| Figure 3.6: Cable Connections From STM to MSDos Computers.....           | 3-7 |
| Figure 3.7: Typical System. ....   | 3-8 |
| Figure 3.8: Head Mounting Dimensions. ....                               | 3-9 |
| Figure 4.1: Typical Tooling Factors. ....                                | 4-3 |
| Figure 5.1: Cable Connection From STM-100 / MF to IBM-AT.....            | 5-1 |
| Figure 5.2: Connections for STM-100 / MF to PC Compatible Computers..... | 5-2 |
| Figure 5.3: BASIC Driver Routine.....                                    | 5-4 |
| Figure 5.4: HP-85 IEEE-488 BASIC Driver Program.....                     | 5-7 |
| Figure 6.1: Sensor and Feed Through Connections. ....                    | 6-3 |
| Figure 6.2: Test Oscillator OSC-100A. ....                               | 6-3 |
| Figure 6.3: SM75, MicroDot <sup>®</sup> Connector. ....                  | 6-4 |
| Figure C.1: SHMX-4 Front Panel.....                                      | 0-1 |
| Figure C.2: SHMX-4 Back Panel.....                                       | 0-2 |
| Figure C.3: SHMX-4 to STM-100 Control Cable.....                         | 0-2 |

## List of Tables

|   |      |
|---|------|
| Table 2.1: Baud Rate Switch Settings .....                  | 2-10 |
| Table 2.2: Configuration Switch Address Settings.....       | 2-11 |
| Table 4.1: Common Material Reference Table.....             | 4-4  |
| Table 4.1: Common Material Reference Table, Continued ..... | 4-5  |
| Table 4.1: Common Material Reference Table, Continued ..... | 4-6  |
| Table 5.1: Baud Rate Configuration Table.....               | 5-2  |
| Table 5.2: Communication Command Summary.....               | 5-8  |

# **SECTION 1**

*General Information*



## GENERAL INFORMATION

### INTRODUCTION

The STM-100 / MF from Sycon Instruments, Inc. represents a new class of thin film monitor. It uses the time-proven 6 MHz oscillating quartz crystal as the sensor device. The STM-100 / MF is constructed with advanced LSI and microprocessor technology. This enables the direct solution of the complex mathematical equation associated with the frequency shift versus mass loading characteristics of the quartz crystal sensor. Its computational power allows the measurement of the material accumulated on the sensor crystal to be accurately converted to film thickness using the exact equation; inaccuracies due to approximations and limited ranges of material constants do not contribute to thickness and rate errors. A high frequency period measurement clock (over 70 MHz) enables the STM-100 / MF to make and display 4 measurements/second with one-tenth Angstrom rate resolution. The STM-100 / MF is equipped with 4 setpoint relays, 4 remote inputs, a computer interface (RS-232) supporting 2 protocols including SECS-II, and a high resolution analog recorder output. A rack mount for half-rack mounting is also standard. If desired, the front panel LCD can be configured, by rear panel switch setting, to display the frequency of the sensing crystal instead of computed rate and thickness. STM-100 / MF 's manufactured and shipped after October 1990 have the additional capability of storing film parameter for nine film or processes. Earlier STM's can be factory upgraded to include this feature. An extra-cost option is a second computer interface. This factory installed upgrade can be either IEEE-488 or BITBUS.

### **SECTION 1.1**

### UNPACKING

The STM-100 / MF comes with a power cord, and connectors for the RS-232 interface, the I/O interface and analog output. If the OSC-100 or crystals were ordered at the same time, they will also be included. The unit is shipped with the rack mount attached, which may be removed for table top operation. To complete a system installation a sensing head and a vacuum to air feedthrough are required. Schematic drawings and a MSDOS Format diskette of demonstration software are included with this manual. Refer to Appendix A for a detailed description of the included software. The unit comes set for the line voltage as ordered. If you need to change it, refer to Section 3.2. Make sure that you install the correct fuses when changing line voltage. If it is ever necessary to return the unit to Sycon, for any reason, call and obtain an Return Authorization (RA) number before returning the unit.

### **SECTION 1.2**

**SECTION 1.3**

**STM-100 / MF SPECIFICATIONS**

|                               |                                 |
|-------------------------------|---------------------------------|
| DISPLAY TYPE .....            | 7 DIGIT LCD                     |
| THICKNESS DISPLAY RANGE ..... | 0 to 999.9 kÅ                   |
| RESOLUTION .....              | 1 Å autoranged                  |
| # DIGITS.....                 | 4                               |
| <br>                          |                                 |
| RATE DISPLAY RANGE .....      | 0.0 to 999 Å/S                  |
| RESOLUTION .....              | 0.1 Å/S autoranged              |
| # DIGITS.....                 | 3                               |
| <br>                          |                                 |
| MEASUREMENT PERIOD.....       | 0.25 SEC                        |
| SENSOR TYPE .....             | Quartz Crystal Microbalance     |
| FREQUENCY .....               | 6 MHz Plano Convex A/T Cut      |
| MAX. FREQ. SHIFT .....        | 1 MHz                           |
| <br>                          |                                 |
| FILM PARAMETER.....           | 9 MATERIALS                     |
| VARIABLES.....                | 7                               |
| FILM #.....                   | 1 to 9                          |
| MATERIAL. DENSITY .....       | 0.500 to 99.99 gm/cc            |
| MATERIAL. Z FACTOR.....       | 0.100 to 9.999                  |
| SYS. TOOLING .....            | 10.0 to 399 %                   |
| SHUTTER CLOSURE .....         | 0.000 to 9999 kÅ                |
| THICKNESS SETPOINT .....      | 0.000 to 9999 kÅ                |
| TIMER SETPOINT .....          | 00:00 to 99:59 M:S              |
| <br>                          |                                 |
| I/O CONNECTION .....          | 15 PIN D MALE                   |
| HARDWARE OUTPUTS.....         | 4, SPST 2.5A RELAYS             |
|                               | - Shutter Relay (Pins 5,6)      |
|                               | - Thickness Setpoint (Pins 7,8) |
|                               | - Sensor Failure (Pins 1,2)     |
|                               | - Timer Setpoint (Pins 3,4)     |
| HARDWARE INPUTS.....          | 4 TTL COMP., ACTIVE LOW         |
|                               | - Open Shutter (Pin 12)         |
|                               | - Close Shutter (Pin 11)        |
|                               | - Zero Thickness (Pin 10)       |
|                               | - Zero Timer (Pin 9)            |
|                               | Note: Pins 13,14,15 are GND.    |
| <br>                          |                                 |
| ANALOG RECORDER.....          | ± 10V F.S. RATE OR THICKNESS    |
|                               | - 2 mA max Load,                |
|                               | - 11 BIT Resolution             |
| CONNECTION .....              | Miniature Stereo Jack           |
| STD. COMMUNICATIONS I/O.....  | RS-232, DUAL PROTOCOL           |
|                               | - 4 BAUD RATES                  |
|                               | - 300,1200,2400,9600            |
| CONNECTION .....              | - 9 PIN "D" FEMALE              |

|                             |   |
|-----------------------------|---|
| OPTIONAL COMMUNICATIONS I/O |   |
| 1).....                     | IEEE-488 T/L                                    |
| CONNECTION.....             | - 24 PIN TYPE 57 FEMALE                         |
| 2).....                     | BITBUS Slave Node                               |
| CONNECTION.....             | - 2 TWINAX BNC's                                |
| DISPLAY FUNCTIONS           |   |
| 1) .....                    | DATA/FILM #                                     |
| 2) .....                    | THICKNESS / RATE                                |
| 3) .....                    | CRYSTAL % USAGE / TIMER                         |
| 4) .....                    | SENSOR FREQUENCY                                |
| DISPLAY ANNUNCIATORS.....   | STATUS  |
| RELAY .....                 | ON/OFF EACH RELAY                               |
| PARAMETER ID.....           | EACH VARIABLE                                   |
| MODE ID .....               | PROGRAM / OPERATE                               |
| ACTIVITY.....               | COMMUNICATIONS INTERFACE                        |
| KEYBOARD FUNCTIONS .....    | 8 KEYS  |
| TYPE.....                   | Individual Buttons                              |
| FUNCTIONS.....              | - Shutter Open                                  |
|                             | - Shutter Close                                 |
|                             | - Zero Thickness & Time                         |
|                             | - Set Program Mode On / Off                     |
|                             | - Increase Value                                |
|                             | - Decrease Value                                |
|                             | - Enter Data                                    |
|                             | - Crystal Status                                |
| USER OPTION SWITCHES .....  | Rear Panel                                      |
|                             | - Baud Rate Selection                           |
|                             | - Serial Protocol Selection                     |
|                             | - Communications Address                        |
|                             | - Parameter Lock                                |
|                             | - Negative Limit Operation                      |
|                             | - Frequency Meas. Mode                          |
|                             | - Analog Recorder Function                      |
| POWER REQUIREMENTS.....     | 120/240V,+5%-                                   |
| .....                       | 20%,50/60Hz,10VA                                |
| CONNECTOR.....              | IEC Standard                                    |
| POWER SWITCH.....           | Rear Panel Mounted                              |
| TEMPERATURE RANGE.....      | 0 <sup>o</sup> C to 50 <sup>o</sup> C Operating |
|                             | -15 <sup>o</sup> C to 65 <sup>o</sup> C Storage |
| SIZE / WEIGHT .....         | 2.5"H, 7.25"W, 10"D 4lbs                        |
| (RACK MOUNTED).....         | 3.5"H, 8.0"W, 10"D ;                            |
| SHIP WEIGHT .....           | 8lbs  |

**SECTION 1.4**

**SENSOR SPECIFICATIONS**

Low Profile P/N 500-042

RIGHT ANGLE P/N 500-088

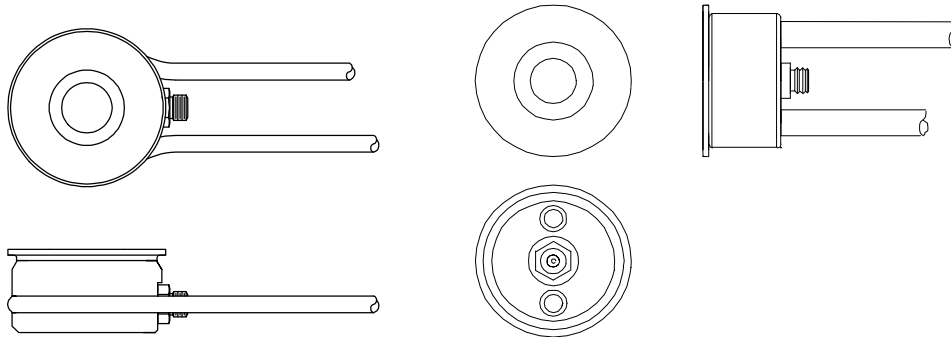

Figure 1.1: Standard Sensors.

Low Profile and Right Angle sensors, See Appendix B for dimensions and more detailed drawings of these and other sensor packages.

**OPERATION**

- Maximum Temperature..... 175° C
- Water Line and Coax Length ..... 30 inches
- Sensor Mounting ..... Rear of Body, 4-40 Tapped Holes

**FEEDTHROUGH INSTALLATION**

**WATER**

- Connections ..... Two Required
- Type ..... 1/8 inch O.D. Stainless Tubing
- Flow Rate..... 0.2 to 0.3 gal/min
- Water Temp..... 50° C max.

**ELECTRICAL**

- Connections ..... One Coaxial Line
- Type ..... Microdot Miniature S-50

**MATERIALS (IN VAC)**

- Body and Water Lines ..... 304 Stainless
- Insulators ..... Alumina
- Coax Insulator ..... Teflon
- Coax Conductor and Shields ..... Copper/Silver
- Braze Material ..... High Vac Ni/CR/Cu Alloy
- Crystal ..... Quartz with Gold Electrodes

**SENSOR SPARE PARTS**

**SECTION 1.5**

| Description                        | SYCON Part Number |
|------------------------------------|-------------------|
| Sensor Body (Standard) .....       | 550-219           |
| Snap Spring .....                  | 024-002           |
| Sensor Cap .....                   | 550-218           |
| 30 inch In-Vacuum Coax Cable ..... | 500-024           |
| 10 inch In-Vacuum Coax Cable ..... | 500-023           |
| Crystals (box of 10) .....         | 500-117           |



**STM-100 / MF PARTS & ACCESSORIES**

| ASSEMBLY                                | PART NUMBER |
|---|-------------|
| STM-100 / MF (Multi Film).....          | 500-104     |
| POWER CORD (120 VAC) .....              | 600-004     |
| FUSES (1/4 A Slow Blow for 120VAC)..... | 356-005     |
| FUSES (1/8 A Slow Blow for 240VAC)..... | 356-007     |
| RECORDER PLUG .....                     | 404-007     |
| I/O 15 PIN CONNECTOR .....              | 404-008     |
| RS-232 9 PIN CONNECTOR .....            | 404-009     |
| MANUAL .....                            | 518-000     |
| CONNECTOR KIT .....                     | 514-001     |
| 19" Rack Mount (Single) .....           | 014-008     |
| 19" Rack Mount (Dual) .....             | 014-009     |
| <br>                                    |             |
| 1" BOLT STANDARD .....                  | 500-016     |
| 2 3/4" ConFlat STANDARD .....           | 500-017     |
| <br>                                    |             |
| LOW PROFILE .....                       | 500-042     |
| RIGHT ANGLE .....                       | 500-088     |
| <br>                                    |             |
| IEEE-488 BUS INTERFACE .....            | 500-021     |
| BITBUS INTERFACE .....                  | 500-022     |
| <br>                                    |             |
| 30" IN-VACUUM COAX CABLE .....          | 500-024     |
| 10" IN-VACUUM COAX CABLE .....          | 500-023     |
| 10' OSC TO STM CABLE .....              | 500-026     |
| 30' OSC TO STM CABLE .....              | 500-027     |
| 6" OSC TO FEED THRU COAX.....           | 500-025     |
| <br>                                    |             |
| BOX OF 10 .....                         | 500-117     |

**SECTION 1.6**

**MONITOR**

**FEEDTHROUGHS**

**SENSORS**

**OPTIONS**

**ACCESSORIES**

**SENSOR CRYSTALS**

# **SECTION 2**

*Operation and Programming*



# OPERATION AND PROGRAMMING

## KEYBOARD DESCRIPTION

The STM-100 / MF keyboard is divided into two separate functional groups. The keys to the left of the LCD display are system control keys and the keys to the right of the display are data entry and programming keys. All keys are sensed when depressed and must be released to cause further action. The exceptions to this rule are the (LIFE) and (ARROW) keys. These keys will cause continuous action if held depressed. An audible beep will accompany each key activation. The beeper may be disabled if desired. See Section 2.7.

### SECTION 2.1

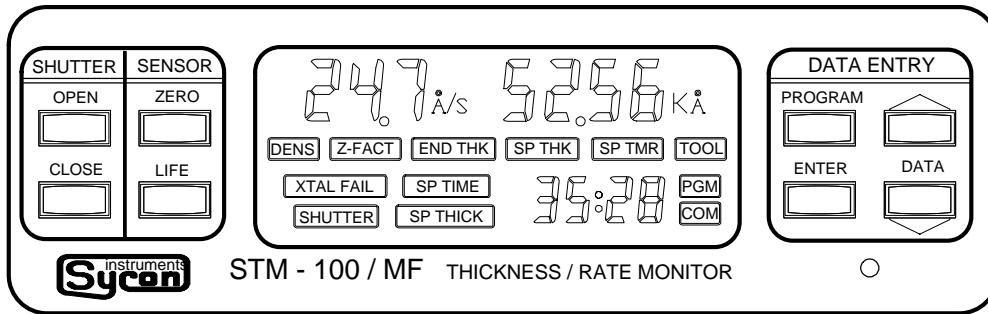

Figure 2.1: STM-100 / MF Front Panel.

## SYSTEM CONTROL KEY GROUP

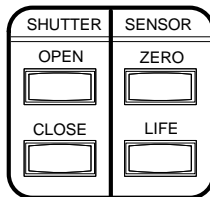

Figure 2.2: System Control Keys.

### SHUTTER OPEN

Activating the SHUTTER OPEN key will cause the internal shutter relay contacts to close. This relay is typically used to control a deposition system source shutter. The LCD display (SHUTTER) legend will be visible when the shutter relay is active. This key is active at all times and states (Program and Normal) of the STM-100 / MF. A remote input duplicating this key function is also provided.

### SHUTTER CLOSE

The SHUTTER CLOSE key provides the reverse function of the SHUTTER OPEN key. This key is active at all times and states of the STM-100 / MF. A remote input duplicating this key function is also provided.

### ZERO

The ZERO key provides two functions, "THICKNESS ZERO" and "TIMER ZERO". Activating the key will cause any accumulated reading in the thickness display to be set to zero, thus providing a new accumulation reference point. It will also reset the elapsed timer and display to the setpoint value contained in the program memory.

### SECTION 2.2

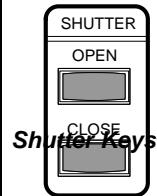

Shutter Keys

### ZERO Key



Any setpoint relays that may have been closed at the time of the "ZERO" key operation will be reset to the open state. This key is inactive in the PROGRAM mode. Remote inputs providing separate operation of the THICKNESS ZERO and TIMER ZERO operations are also provided. *Note that during a Crystal Fail condition, the Zero key does not function.*

**Crystal Life Key**

**LIFE**



Activating the CRYSTAL LIFE key will provide the user with a measure of remaining possible sensor crystal life. This information is expressed in percent with 100% representing a new sensor crystal and 0% indicating a fully loaded sensor crystal (1MHz frequency shift). This information is presented where rate information is normally shown. This data should serve as an indicator for the need to change the sensor crystal. The frequency of the sensor crystal to the nearest kilohertz is also presented. This information is shown where accumulated thickness data is normally displayed. A new sensor crystal should indicate close to 99% life and a frequency near 5.950 MHz. This key function is inactive in the PROGRAM mode. Activating this key during a CRYSTAL FAIL condition may result in a blank data display. The LIFE display is active as long as the LIFE key is held depressed.

**SECTION 2.3**

**DATA ENTRY AND PROGRAMMING GROUP**

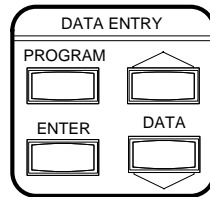

Figure 2.3: Data Entry And Programming Keys.

## PROGRAM

Activation of the PROGRAM key places the instrument in a mode wherein the internal parameter variables may be viewed or modified. Data view operation is always available whereas, data modification may be inhibited by a user option switch on the rear panel. If the instrument is in the PROGRAM mode, depressing the PROGRAM key will return the unit to the normal display mode. Six variable parameters, for each of nine films of the STM-100 / MF may be programmed by the user. Two of these material constants are needed to provide correct thickness and rate information for a particular film material and one is a constant used to correct for system sensor and substrate geometry variations. Three setpoint variables are provided to activate relay events. Two of these are related to thickness and one to elapsed time. These variables and their meanings are discussed in detail in Section 2.4.

## ENTER

The ENTER key has two functions. It is used (1) to sequence through the six parameter variables, one parameter for each press of the ENTER key, and (2) to place modified variable data into the non-volatile storage memory of the instrument. This data will be retained until modified by the user even with no power to the instrument. A legend on the LCD display will indicate which variable parameter data is being displayed. Any modifications to parameter data occur in the display memory only, and will cause the associated parameter legend to flash. The flashing legend indicates that a parameter change has been made but has not yet been saved in memory. To store the data in memory the ENTER key must be pressed. Exiting the PROGRAM mode (via the PROGRAM key) while a parameter legend is flashing does not cause the modified data to be saved. Previously saved parameter data will be retained. The ENTER key only functions in the PROGRAM mode.

## ARROW KEYS

The ARROW keys are used to select the active film and to increment or decrement the displayed parameter variable data in order to achieve the desired value. The rate of incremental change will increase as the key is held depressed. This will speed up parameter changes covering a large dynamic data range. Letting up on the key and then resuming key depression will reset the rate of change to the slowest rate and it will again increase with time as the key remains depressed.

### Program Key



### Enter Key



### Arrow Keys



## FILM PARAMETERS

### SECTION 2.4

The STM-100 / MF utilizes a high contrast liquid crystal display for the viewing device. All measurement data, instrument status, and program variable operations are viewable on the display. A three or four digit parameter display and a four digit time display (min:sec) are used to display the dynamic data.

### LCD Data Displays

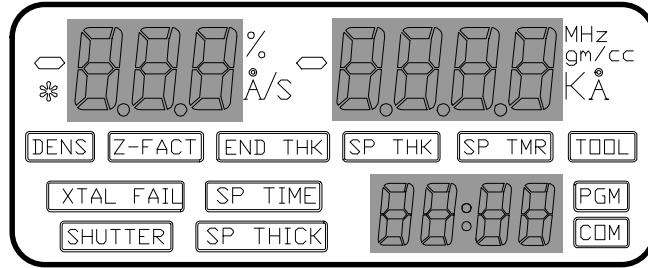

Figure 2.4: LCD Data Areas.

The STM-100 / MF incorporates six programmable parameter variables for each of nine films programmable by the user. Three variables are used by the thickness equation and are related to material physical constants and system geometry (Density, Z-Factor, and Tooling). The three remaining parameters are used as setpoint values to activate the internal relays on the I/O connector.

Each variable has a specific LCD legend associated with it. These legends are only active in the PROGRAM mode and only one will be on at a time. Each parameter is discussed in more detail below.

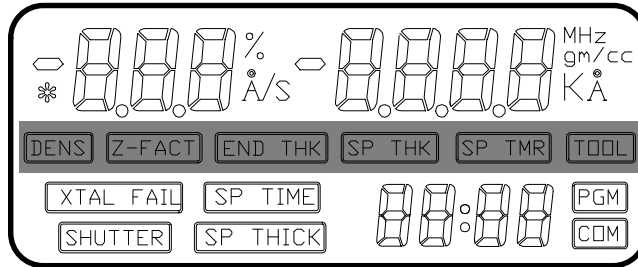

Figure 2.5: LCD Variable Parameter Legends.

### Film Number Parameter

After entering the program mode by pushing the Program Button the current film number is displayed in the upper left hand corner of the LCD display. (FL.n, n is 1 through 9). Refer to Figure 2.6.



Figure 2.6: Film Number Parameter.

At this point the current film's parameters may be reviewed or changed or a new current film selected. To select a new current film the film number is increased or decreased by using the up and down arrow keys. Pushing the enter button selects the film number shown to be the current film and displays the first parameter (density) of that film. Each of the film parameters can now be reviewed or changed by using the DATA keys and / or the ENTER key.

**WARNING**



When leaving the Program Mode, the last Selected FILM is the current active FILM.

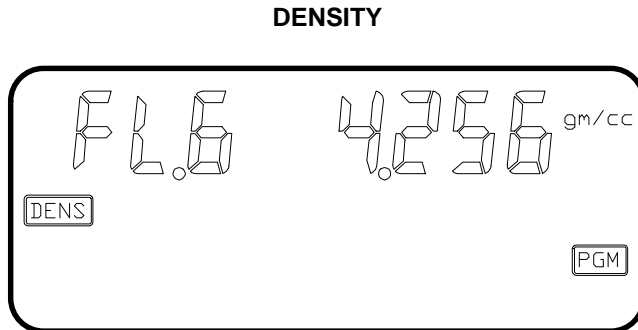

Figure 2.7: Density Parameter.

|        |                |
|--------|----------------|
| LEGEND | DENS           |
| RANGE  | 0.500 to 99.99 |
| UNITS  | gm/cc          |

The DENSITY parameter refers to the measured material density in gm/cc. This constant is normally the bulk material value but is sometimes different due to deposition and film growth conditions. This value is utilized in the thickness equation to convert measured mass to a thickness value. See Table 4.1 for an extensive value list. See Section 4.2 for calibration information.

*Density Parameter*



## Z-FACTOR

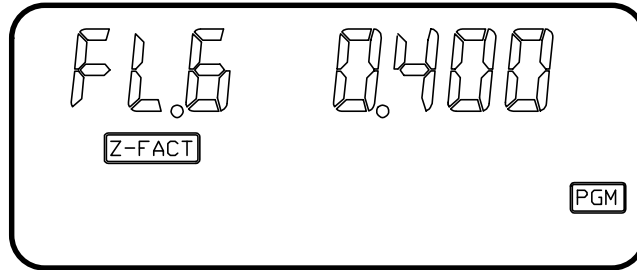

Figure 2.8: Z-Factor Parameter.

|        |                |
|--------|----------------|
| LEGEND | Z-FACT         |
| RANGE  | 0.100 to 9.999 |
| UNITS  | NONE           |

### Z-Factor Parameter

The Z-Factor parameter refers to the elastic properties of the measured material. This value is utilized in the thickness equation to match the acoustical properties of the film being measured to the acoustic properties of the base quartz material of the sensor crystal. This correction is necessary to insure accurate measurements when sensor crystal shifts of greater than 15% are realized. See Table 4.1 for an extensive material value list. See Section 4.2 for calibration information.

## END THICKNESS

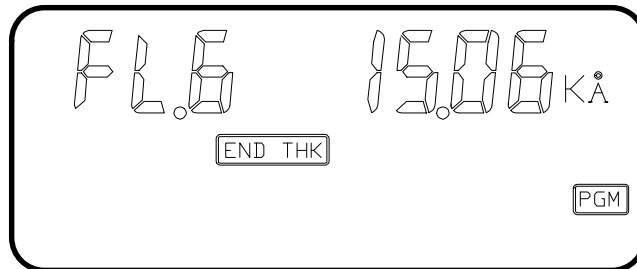

Figure 2.9: End Thickness Parameter.

|        |   |
|--------|---|
| LEGEND | END THK   |
| RANGE  | 0 to 9999                                       |
| UNITS  | KILO ANGSTROMS (1 Angstrom = $10^{-10}$ meters) |

### End Thickness

The END THICKNESS parameter is used to provide a trigger setpoint for the STM-100 / MF Shutter Relay contacts. If the shutter relay contacts are closed by operating the front panel shutter closed button or by remote input. These contacts will return to the open state when the thickness display value becomes equal to or exceeds the END THICKNESS SETPOINT value.

The STM-100 / MF Shutter Relay contacts are normally used to automatically control a deposition system source shutter. This is a trigger event and will only effect shutter status at the time the event occurs. If the shutter relay contacts were already open at the time of the event the event will be ignored. A setpoint value of 0.000 kÅ causes the setpoint function to be ignored.

### SETPOINT THICKNESS

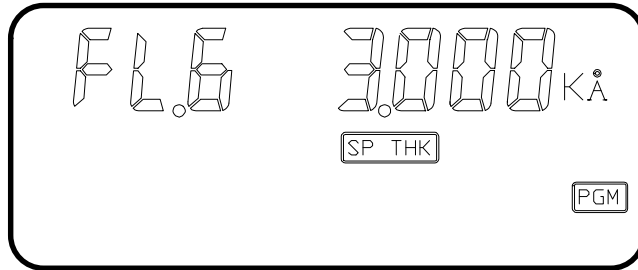

Figure 2.10: Set Point Thickness Parameter.

|        |                |
|--------|----------------|
| LEGEND | SP THK         |
| RANGE  | 0 to 9999      |
| UNITS  | KILO ANGSTROMS |

The SETPOINT THICKNESS parameter is used to provide a comparison point for the STM-100 / MF Thickness Setpoint Relay. This set of relay contacts will be closed whenever the thickness display equals or exceeds the setpoint value. A setpoint value of 0.000 kÅ causes the thickness setpoint function to be ignored.

*Setpoint Thickness Parameter*

### SETPOINT TIMER

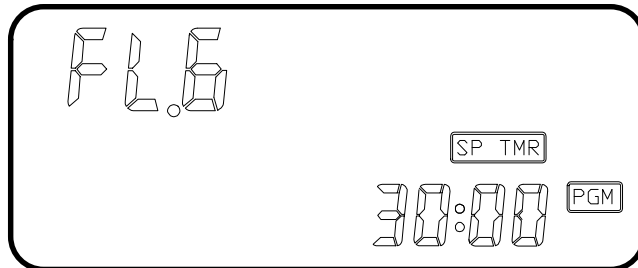

Figure 2.11: Set Point Timer Parameter.

|        |                |
|--------|----------------|
| LEGEND | SP TMR         |
| RANGE  | 00:00 to 99:59 |
| UNITS  | MIN:SEC        |

The SETPOINT TIMER parameter is used to provide a comparison point for the STM-100 / MF Timer Setpoint Relay. The internal STM-100 / MF timer is pre-set with the setpoint value whenever the front panel ZERO key, or a remote ZERO TIMER input, is activated. The Timer Relay contacts are opened at this time and the timer display begins counting downward toward zero. When the timer display reaches zero the relay

*Setpoint Timer*

contacts are closed and the display timer begins counting in an upwards fashion. A setpoint value of 00:00 will cause the timer setpoint function to be ignored.

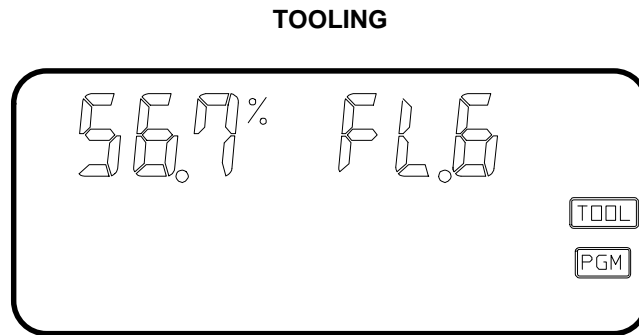

Figure 2.12: Tooling Parameter.

|        |             |
|--------|-------------|
| LEGEND | TOOL        |
| RANGE  | 10.0 to 399 |
| UNITS  | PERCENT     |

#### ***Tooling Factor Parameter***

The TOOLING parameter is used as a correction factor to compensate for geometric position differences between the location of the sensor and the target substrate. Correction is required both the substrate and sensor see the material source in an identical manner, unless for this case, the Tooling Parameter is set to 100%. Generally, if the sensor is farther from the source than the substrate, the tooling will be set to >100%. If the sensor is closer to the source, the tooling will be set to < 100%. See Section 4.2 for calibration information.

## USER CONFIGURATION SWITCHES

## SECTION 2.5

On the rear panel of the STM-100 / MF a twelve selection configuration switch is located. The settings of this switch allow the user to select various system operational modes. All communications related variables are also set here. Switches 1 thru 4 may be changed at any time and will have immediate effect. Switches 5 thru 12 are only read at the time of power turn on.

### CONFIGURATION SWITCH

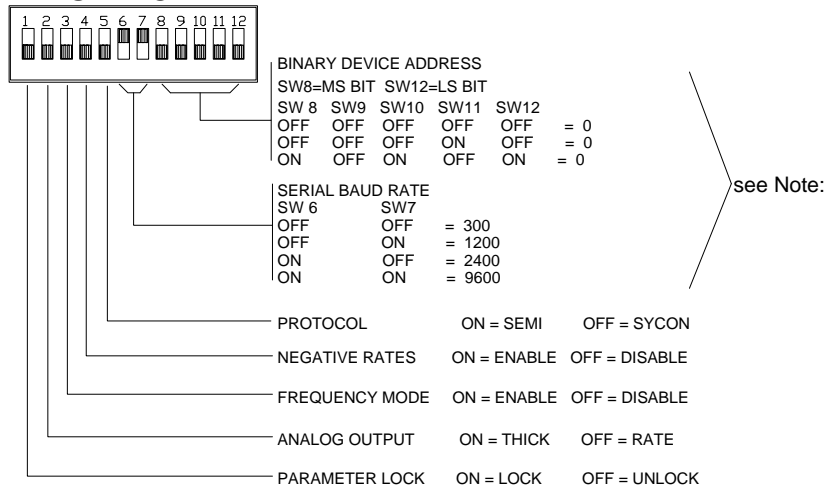

NOTE: Switch settings involving communications functions are sensed at power up only.

Figure 2.13: Configuration Switch Settings.

### SWITCH FUNCTION DEFINITIONS

#### SW1 - PARAMETER LOCK

When on, stored parameter data cannot be modified via the front panel. *This switch is sensed at all times.*

#### SW2 - RECORDER FUNCTION

When on, the analog output will provide thickness information. Rate information is presented in the off state. *This switch is sensed at all times.* See Section 3.6.

#### SW3 - FREQUENCY MODE

When on, the unit will display seven digits of sensor frequency to a resolution of one Hertz. All other instrument functions remain normal. *This switch is active at all times.*

#### SW4 - NEGATIVE LIMITS

When on, both thickness setpoints and their associated relays will activate on negative thickness data only. *This switch is sensed at all times.*

#### SW5 - SERIAL COMMUNICATIONS FORMAT

When on, the RS-232 serial communications channel will respond to SEMI STANDARD SECS-II formatted commands. Sycon formatted

Configuration

commands are valid for the off state. *This switch is sensed only at power-up.*

#### SW6 & SW7 - BAUD RATE SELECTION

These two switch settings in combination select one of four baud rates for the RS-232 serial communications channel. *These switches are sensed only during power-up.*

| <b>SW6</b> | <b>SW7</b> | <b>BAUD</b> |
|------------|------------|-------------|
| OFF        | OFF        | 300         |
| OFF        | ON         | 1200        |
| ON         | OFF        | 2400        |
| ON         | ON         | 9600        |

Table 2.1: Baud Rate Switch Settings

#### SW8, SW9, SW10, SW11, SW12 DEVICE ADDRESS SELECTION

These switches in combination select the device address for the instrument when operating with the SECS RS-232 protocol or with either the IEEE-488 or BITBUS communications option cards. These options allow multiple devices to operate on a single bus, and only the individual addressing prevents response conflicts. Switch coding is in binary 1 of 32 format with SW8 the MSB and SW12 the LSB. These switches are sensed only during power-up. See Table 2.2 for a list of addresses.

| Switch Setting |     |      |      |      | Address |                  |
|----------------|-----|------|------|------|---------|------------------|
| SW8            | SW9 | SW10 | SW11 | SW12 | IEEE    | BITBUS / SECS II |
| off            | off | off  | off  | off  | 0       | 32 / 0           |
| off            | off | off  | off  | on   | 1       | 1                |
| off            | off | off  | on   | off  | 2       | 2                |
| off            | off | off  | on   | on   | 3       | 3                |
| off            | off | on   | off  | off  | 4       | 4                |
| off            | off | on   | off  | on   | 5       | 5                |
| off            | off | on   | on   | off  | 6       | 6                |
| off            | off | on   | on   | on   | 7       | 7                |
| off            | on  | off  | off  | off  | 8       | 8                |
| off            | on  | off  | off  | on   | 9       | 9                |
| off            | on  | off  | on   | off  | 10      | 10               |
| off            | on  | off  | on   | on   | 11      | 11               |
| off            | on  | on   | off  | off  | 12      | 12               |
| off            | on  | on   | off  | on   | 13      | 13               |
| off            | on  | on   | on   | off  | 14      | 14               |
| off            | on  | on   | on   | on   | 15      | 15               |
| on             | off | off  | off  | off  | 16      | 16               |
| on             | off | off  | off  | on   | 17      | 17               |
| on             | off | off  | on   | off  | 18      | 18               |
| on             | off | off  | on   | on   | 19      | 19               |
| on             | off | on   | off  | off  | 20      | 20               |
| on             | off | on   | off  | on   | 21      | 21               |
| on             | off | on   | on   | off  | 22      | 22               |
| on             | off | on   | on   | on   | 23      | 23               |
| on             | on  | off  | off  | off  | 24      | 24               |
| on             | on  | off  | off  | on   | 25      | 25               |
| on             | on  | off  | on   | on   | 27      | 27               |
| on             | on  | on   | off  | off  | 28      | 28               |
| on             | on  | on   | off  | on   | 29      | 29               |
| on             | on  | on   | on   | off  | 30      | 30               |
| on             | on  | on   | on   | on   | 0       | 31               |

Table 2.2: Configuration Switch Address Settings

## TEST MODE

### SECTION 2.6

#### *Enabling the Test Mode*

The STM-100 / MF incorporates a test and deposition simulation mode to aid in trouble shooting and demonstrating the instrument. This mode simulates a deposition rate of 16 Angstroms per second with a Density and Z-Factor of 1 and Tooling of 100%. The test mode may be activated only in the non-program mode. Holding the UP ARROW key down while activating the SHUTTER CLOSE key will turn the test mode on. The Å/S and KÅ legends will blink continuously to indicate the test function. Once in the test mode the shutter open and close buttons control the simulated deposition. The test mode may be turned off by holding the UP ARROW key depressed and then activating the SHUTTER OPEN key. Turning the unit off and back on also clears the test mode.

## BEEPER

### SECTION 2.7

#### *Disabling the Beeper*

The beeper will give a short audible tone when any key is depressed or the unit power switch is turned on. The keyboard beeper may be disabled if desired by holding the DOWN ARROW key and activating the SHUTTER CLOSE key while not in the PROGRAM mode. The same procedure and activating the SHUTTER OPEN key will turn the beeper on. The beeper will always be enabled after power is applied to the unit.

# **SECTION 3**

*Installation*





# INSTALLATION

## Electrical Connections and Descriptions

All electrical connections to the STM-100 / MF are made at the rear panel of the instrument. Care should be exercised in routing all cables as far as practically possible from any other cables or wires that may be generating noise. These may include other line voltage cables, wires to heaters that are SCR-controlled, and wires or cables that may conduct high transient currents during arc over of an E-beam type supply.

**SECTION 3.1**

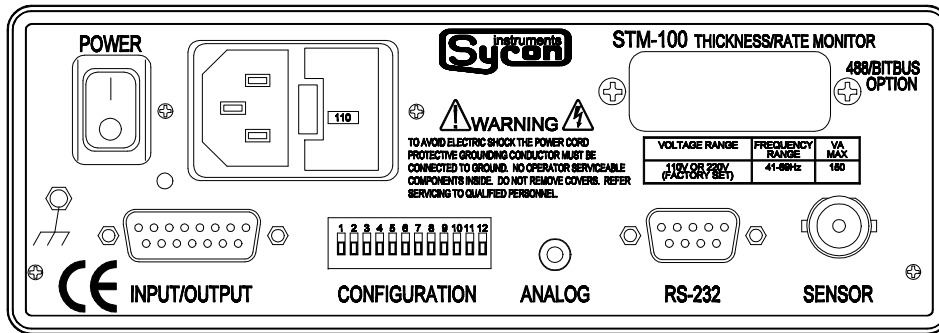

Figure 3.1: Rear Panel.

**SECTION 3.2**

*Line Power Warning*

**WARNING**



OPERATING THE STM-100 / MF AT 220V WHEN THE UNIT IS CONFIGURED FOR 110V MAY CAUSE DAMAGE TO THE UNIT.

REPLACE BROKEN OR BLOWN FUSES ONLY WITH TYPE 3AG SLOW BLOW OR EQUIVALENT WITH THE RATINGS SPECIFIED. FAILURE TO DO SO MAY RESULT IN UNSAFE OPERATION AND MAY CAUSE DAMAGE TO THE UNIT.

The STM-100 / MF may be configured to operate on either 110V or 220V nominal line voltage. Units are factory-shipped configured for 110V operation unless otherwise ordered. The setting may be verified by noting the line voltage value visible in the small window of the power and fuse module. To change the configuration first remove the power cord, then release the latch in the center of the module and remove the insert holding the fuses. The insert contains two fuses, the system fuse and a spare. Remove both fuses, then pull the two-prong fuse holder out of the latching insert. Rotate the fuse holder and replace it into the latching insert such that the proper line voltage is visible in the window. The reading will be either 110 or 220. Place the proper fuse into the metal clips (1/4 amp SB for 110V operation and 1/8 amp SB for 220V operation), place the spare fuse into the spare fuse area and replace the latching insert back into the power module. Make sure the latch snaps are closed. Replace the power cord with the proper type for the line voltage chosen. Proper power line cord should be used, the 110V line cord should not be used for 220V operation.

**Line Voltages**

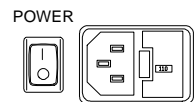

## GROUND

A ground post is provided on the rear panel. This point should be connected to the DEPOSITION SYSTEM GROUND with the shortest convenient length of heavy gauge wire. This connection is not required for normal operation but will make the unit less susceptible to transient noise. See Figure 3.2 for an example of proper installation.

**SECTION 3.3**

**Grounding**

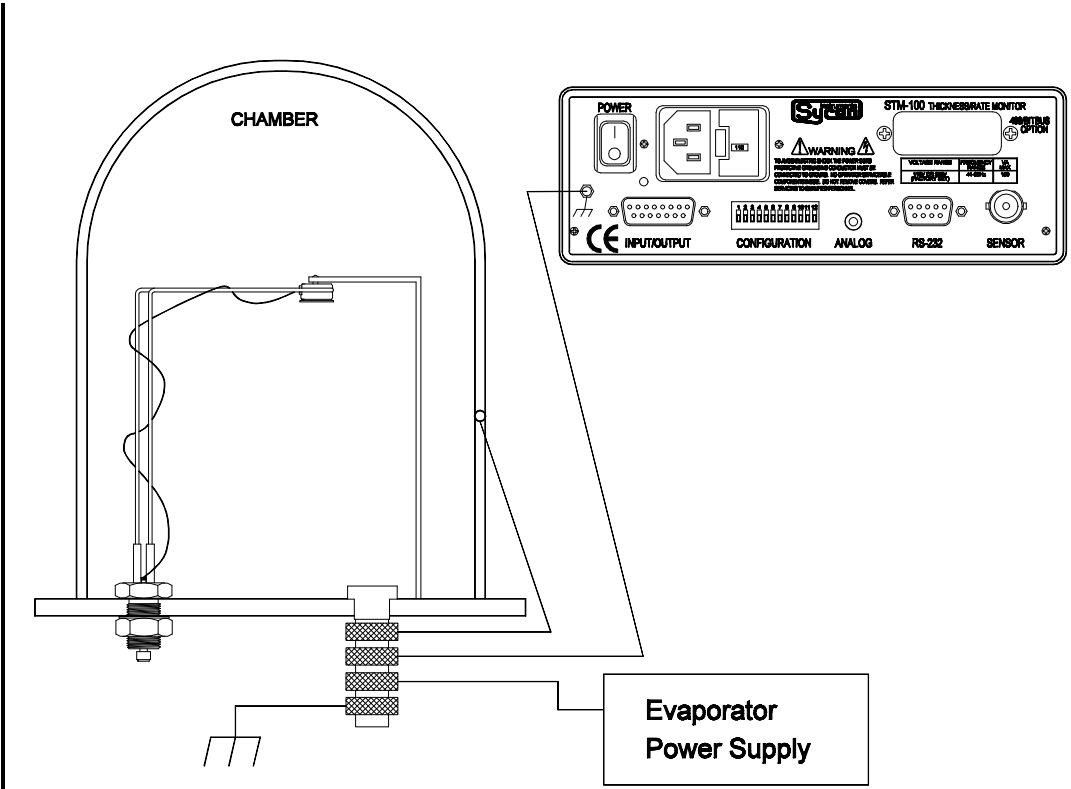

Figure 3.2: Recommended Grounding Procedure.

**CONNECTOR INSTALLATION**

**Connector Shielding**

In systems with a high noise environment, you need to be careful when wiring up connectors. A little extra time spent here can save you hours of frustration later. Sycon provides mating connectors with each instrument. Extra sets of mating connectors are available from Sycon as part number 514-001. For best results, use a shielded multi-conductor cable. On the D-connectors, the metal shells each come with a set of 4 grommets. Pick the grommet for the size cable that you are using. Cut the outer insulation off of the cable so that it is exposed to 3/4 of the grommet. Because the grommet is conductive, no additional shield wiring is needed.

## I/O INTERFACE CONNECTION

This connector provides the user interface to the 4 sets of relay output contacts as well as the 4 remote input command lines.

RELAY CONTACT RATINGS      2.5 AMPS - 120VAC MAX. - 120VA  
Normally Open - SPST CONTACTS

I/O CONNECTOR DEFINITIONS  
TYPE

15 Pin "D" Male

MATING CONNECTOR      AMPHENOL 117-DA15S OR EQUIVALENT

FUNCTION      PIN NUMBER

|                    |            |
|--------------------|------------|
| Crystal Fail       | 1, 2       |
| Elapsed Timer      | 3, 4       |
| Shutter Relay      | 5, 6       |
| Thickness Setpoint | 7, 8       |
| Ground             | 13, 14, 15 |
| Shutter Open       | 12         |
| Shutter Close      | 11         |
| Zero Thickness     | 10         |
| Zero Timer         | 9          |
| Ground             | 13, 14, 15 |

### RELAY OUTPUTS

The STM-100 / MF is standard equipped with four SPST 2.5 AMP relays rated to 120VAC and to 120VA. These contacts are normally open and become active when their respective function is true. Continuous display of the status of each relay is provided by legends on the LCD display. The available relay functions are:

1. CRYSTAL FAIL - This relay provides a contact closure whenever the sensor crystal fails to operate properly or has exceeded its operating range. The LCD legend for this relay status is (XTAL FAIL). The legend will also flash as a warning to the user.
2. ELAPSED TIMER - This relay provides a contact closure when the elapsed timer has counted down to a value of zero from a setpoint value other than zero. A setpoint value of zero disables this relay function. The display will continue to count in an upward fashion after a count of zero is reached. The relay contacts will remain closed until the front panel ZERO button or a remote TIMER ZERO event occurs, or a new timer number is entered. The LCD legend for this relay is (SP TIME).

## SECTION 3.4

*I/O Connector*

*RELAYS*

*INPUTS*

*Relay Outputs*

*Crystal Fail*

*Elapsed Timer*

**Shutter**

3. SHUTTER RELAY - This relay is intended to provide control of a deposition system source shutter. The front panel and remote input OPEN and CLOSE SHUTTER functions directly control this relay. The contacts are closed when the source shutter is intended to be open. The LCD legend for this relay is (SHUTTER). The relay status is also controlled by a END THICKNESS event. This event is controlled by the END THICKNESS setpoint parameter. If the shutter is open at the time of this event it will automatically close. The (SHUTTER) legend will turn off and the (END THICK) legend will become visible, indicating the shutter was closed by the END THICKNESS event.

**Thickness Setpoint**

4. THICKNESS SETPOINT - This relay provides a contact closure whenever the accumulated thickness display value equals or exceeds the thickness setpoint parameter value. This relay function is disabled with a parameter value of zero. The LCD legend for this relay is (SP THICK).

**REMOTE INPUTS**

**Remote Inputs**

The STM-100 / MF is standard equipped with four remote input functions. These inputs are intended to be activated with a contact closure to ground but may also be controlled with TTL level signals. All remote inputs are leading edge detected and can thus remain activated indefinitely. To cause the event to happen again the input must be removed for a minimum of 200 milliseconds and then can be re-applied. The four available input commands are:

**Shutter Relays**

1. REMOTE SHUTTER OPEN - Functionally identical to front panel SHUTTER OPEN button. Activating this input will close the contacts of the SHUTTER RELAY.

**Thickness Zero Input**

2. REMOTE SHUTTER CLOSE - Functionally identical to front panel shutter close button. Activating this input will open the contacts of the SHUTTER RELAY.

**Timer Zero Input**

3. REMOTE THICKNESS ZERO - Sets the accumulated thickness display to zero. Does not zero the elapsed time timer.

4. REMOTE TIMER ZERO - Re-initializes the elapsed time timer. Does not zero accumulated thickness.

**Remote Input Specifications**

**SPECIFICATIONS**

- ACTIVATION ..... Contact closure to gnd or TTL low
- INPUT IMPEDANCE ..... 2700 ohms
- OPEN CIRCUIT VOLTAGE..... 3.5V typical, 5V max.
- MAXIMUM ON VOLTAGE..... 0.6 volts
- MAXIMUM SINK CURRENT ..... 2 mA (1 TTL LOAD)

## SENSOR CONNECTION

### CONNECTION TYPE -- BNC FEMALE

This connection is the REMOTE SENSOR OSCILLATOR interface to the STM-100 / MF. This connection is both the signal and power path to the oscillator. The supplied power is 5 volts at 50 mA. The input impedance is 50 ohms and the signal level is 1 volt peak to peak. The DC voltage may be removed by disconnecting internal STM-100 / MF jumper J1. This may prove useful if a signal source other than the Sycon oscillator is utilized. This connection should always be made with coaxial cable. Type RG58 or RG59 is recommended. Cable lengths up to 500 feet are acceptable. These cables in 10 and 30 foot lengths are available as standard parts from Sycon.

## ANALOG RECORDER INTERFACE

This connector provides an analog output voltage proportional to either displayed RATE or THICKNESS as selected by the user option dip switches on the rear panel of the STM-100 / MF. If SW2 of the user configuration dip switch is set OFF the analog output will report RATE information. If SW2 is ON, the analog output will correspond to THICKNESS information. The output voltage is bipolar and corresponds to the sign of the displayed data.

### CONNECTOR TYPE - MINIATURE STEREO SOCKET

### CONNECTOR MATE - 1/8 inch Miniature Stereo Jack

#### SPECIFICATIONS

|                        |                 |
|------------------------|-----------------|
| RESOLUTION .....       | 11 BITS (0.05%) |
| ACCURACY .....         | 0.3 % FS        |
| LOADING CAPACITY ..... | 2 mA            |
| F.S. OUTPUT .....      | 10 VOLTS        |

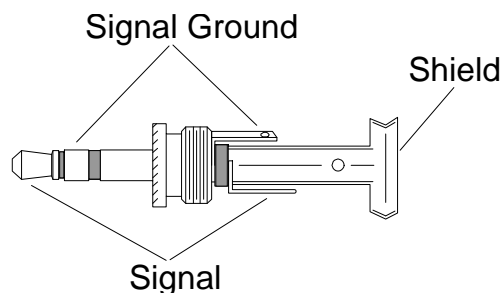

Figure 3.3: Recorder Output Plug.

## RECORDER OUTPUT MATING PLUG CONNECTIONS

|                    |               |
|--------------------|---------------|
| TIP .....          | SIGNAL        |
| INSIDE RING .....  | SIGNAL GROUND |
| OUTSIDE RING ..... | SHIELD        |

**THICKNESS MODE** - The analog recorder output in the thickness mode is always scaled for plus or minus 999 Angstroms full scale (10V). Resolution is always one (1) Angstrom. Display readings above 999 Angstroms will be sent to the recorder output as the remainder of the displayed value divided by 1000.

## SECTION 3.5

### Oscillator Connection

## SECTION 3.6

### Analog Output Specifications

## RECORDER CALIBRATION

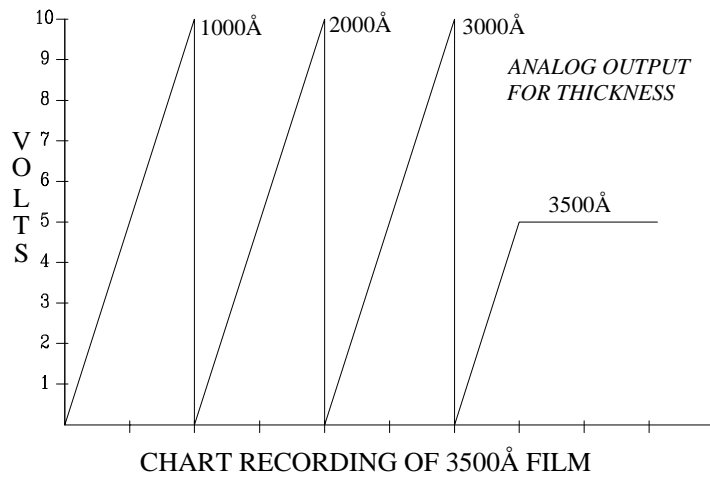

Figure 3.4: Example of Thickness Mode Recorder Output.

**Recorder Outputs**

**RATE MODE** - The analog recorder output for the rate mode is scaled for a full scale (999.9 Å/S) reading of 10 volts. Readings of 0 Å/S to 100 Å/S have a slope to 50 mV per Å/S and above 100.0 Å/S have a slope of 5.555 mV per Å/S. Readings up to 100.0 Å/S will be output with a resolution of 0.1 Å/S and values above 100.0 Angstroms will be output with a resolution of 1.0 Å/S. At a rate of 100 Å/S the recorder output is 5 volts. This method allows a continuous recorder accuracy of at least 0.3% and also provides a unique output voltage for any rate value within the displayable range of values. Negative rate values will be indicated by negative output voltages.

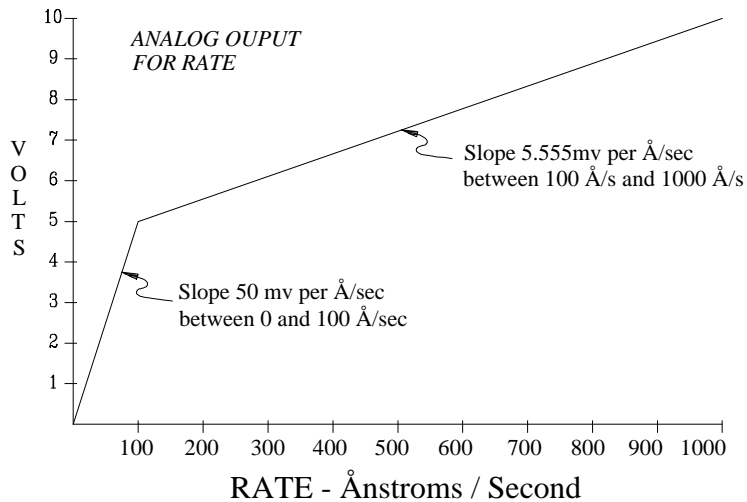

Figure 3.5: Example of Rate Mode Recorder Output.

## RS-232 SERIAL COMMUNICATIONS INTERFACE

### SECTION 3.7

#### RS-232 Connections

This Connection provides a serial transmission data communications link to the STM-100 / MF. Four standard baud can be selected: 300, 1200, 2400, and 9600. They are selected via the rear panel configuration dip switches. (See Section 2.5) The serial interface communications protocol is also selectable on these switches. The choices are SEMI STANDARD SECS-II, or Sycon format. The electrical specifications correspond to the RS-232 standard.

CONNECTOR TYPE            9 PIN "D" FEMALE  
 CONNECTOR MATE           AMPHENOL 117-DA9P OR EQUIVALENT

#### RS-232 CONNECTOR DEFINITIONS

| STM-100 / MF FUNCTION     | PIN NUMBER |
|---------------------------|------------|
| RECEIVED DATA .....       | 2          |
| TRANSMITTED DATA .....    | 3          |
| CLEAR TO SEND .....       | 8          |
| DATA TERMINAL READY ..... | 4          |
| SIGNAL GROUND .....       | 5          |
| CABLE SHIELD .....        | 9          |

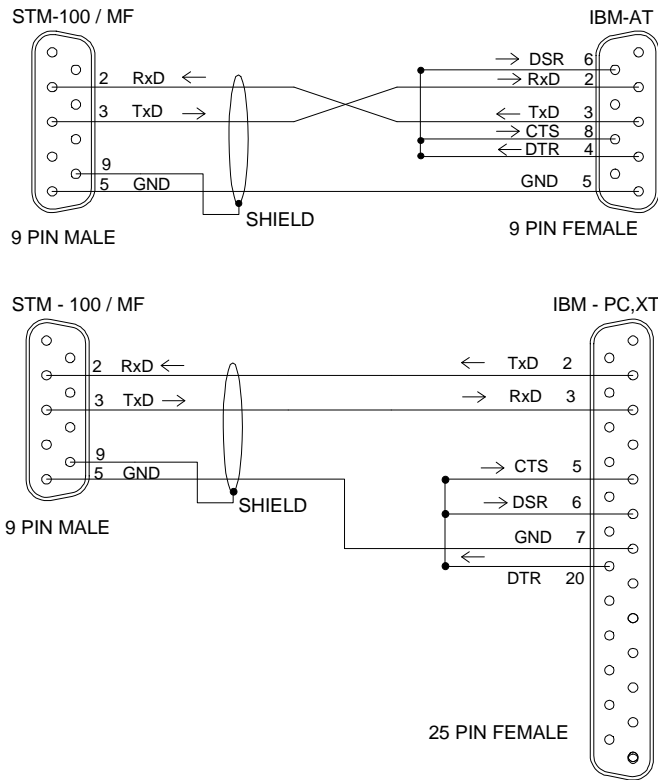

Figure 3.6: Cable Connections From STM to MSDos Computers.



## COMMUNICATIONS OPTIONS

### SECTION 3.8

#### Communications Options

The STM-100 / MF will support two types of communications option boards. Type 1 is the IEEE-488 parallel bus and type 2 is the industrial standard BITBUS. Only one type of option card may be installed at a time. Both cards use the COMM OPTION rear panel cut-out for external connection. Contact the factory for details on having either option installed.

The computer identification address (device address) for either option card is set in the same fashion. Dip switches 8 through 12 on the rear panel of the STM-100 / MF set a binary address from 0 through 31. Switch 8 is the MSB and switch 12 is the LSB. (See Table 2.2) The unit is factory-shipped set for address 0. See Section 5 for a more detailed explanation of the command and addressing limitations.

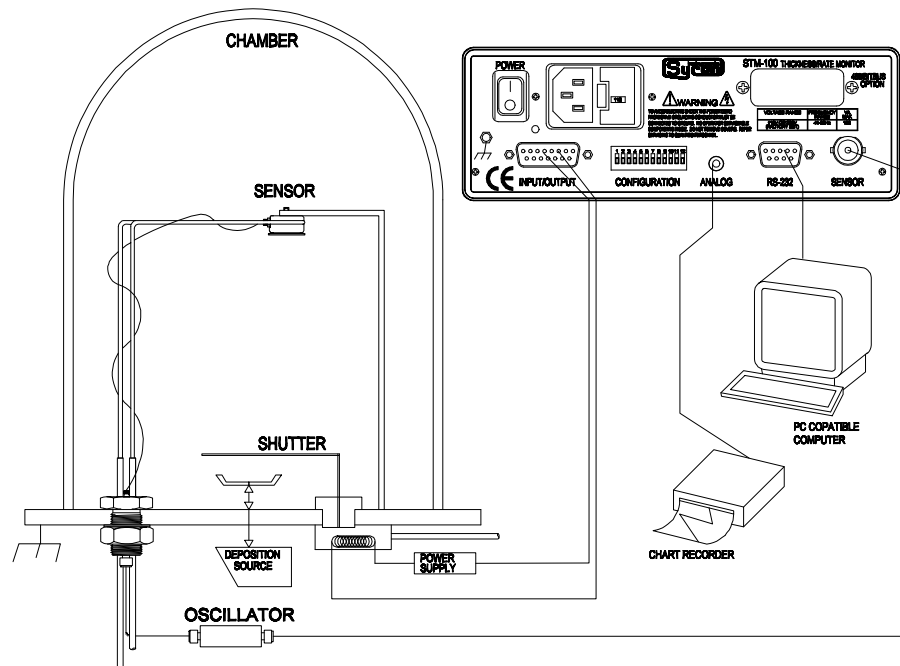

Figure 3.7: Typical System.

## DEPOSITION SYSTEM INSTALLATION

### SECTION 3.9

#### System Installation

Figure 3.7 is a diagram of a typical evaporator installation. Referring to this drawing and following the recommendations below should provide adequate information for most installations. If further assistance is needed contact the customer service and applications department at Sycon.

## SENSOR HEAD INSTALLATION

As a general rule the sensor head should not be installed closer than 10 inches to the evaporation source. This minimum distance will generally provide adequate measurement sensitivity while reducing the possibility of the source spattering small particles onto the sensor. Even small particles hitting the crystal surface may cause the crystal to become unstable or stop oscillating completely. The sensor should be shielded from the evaporant source by a shutter or other means when evaporant material is being initially conditioned or out gassed.

Install the sensor so that the crystal opening is in a direct line with the evaporation source and well within the evaporant stream. Ensure that the sensor is not shadowed by mechanical structures within the vacuum system. The sensor should be held mechanically stable by attaching it to a mounting bracket via the rear #4-40 tapped holes.

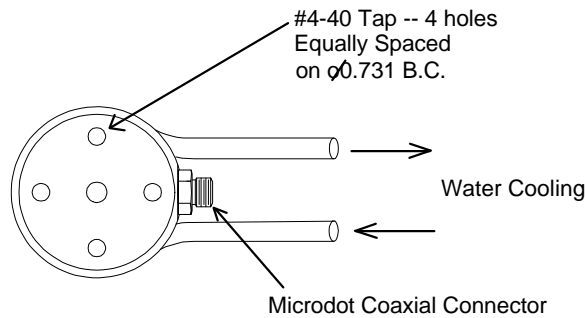

Figure 3.8: Head Mounting Dimensions.

### Installing Water Lines

Bend the two sensor water lines into the desired position for connection to the vacuum feedthrough. Take care not to crimp the lines. There are two methods for attaching the water lines to the feedthrough.

The first is to silver solder or TIG weld the sensor and water lines together. To do this first locate the final position of the sensing head and feedthrough. Trim the 1/4" water lines on the feedthrough to the desired length. Bend and fit the sensor water lines as required. Cut the 1/8" water lines to length allowing 1/4" to 1/2" of extra length to be inserted the 1/4" feedthrough water lines. Then braze, silver solder, or TIG weld.

The second is to use Swagelok compression fittings. These are available from Sycon as part number 022-001. These can also be purchased from Swagelok as part number SS-300-6-2.

**Sensor Installation**

**Water Lines**

## INSTALLING COMPRESSION FITTINGS

SWAGELOK Tube fittings are installed in three easy steps:

- Step 1      Simply insert the tubing into the SWAGELOK Tube Fitting. Make sure that the tubing rests firmly on the shoulder of the fitting and that the nut is finger tight.
- Step 2      Before tightening the SWAGELOK nut, scribe the nut at the 6 o'clock position.
- Step 3      Now, while holding the fitting body steady with a backup wrench, tighten the nut 3/4 of a turn. Watch the scribe mark, and make 3/4 revolution to the 3 o'clock position.

By scribing the nut at the 6 o'clock position as it appears to you, there will be no doubt as to the starting position. When tightened 3/4 of a turn to the 3 o'clock position you can easily see that the fitting has been properly installed

## RE-TIGHTENING INSTRUCTIONS

Connections can be disconnected and re-tightened many times. The same reliable, leak-proof seal can be obtained every time the connection is remade. First tighten the nut by hand. Then rotate the nut to the original position (scribe mark at 3 o'clock) with a wrench. An increase in resistance will be felt near this point. Now tighten an additional 1/8 turn.

## VACUUM FEEDTHROUGH

The vacuum feedthrough should be installed as close as practically possible to the sensor head. This allows the shortest length of sensor-to-feedthrough coax cable to be used. Cable lengths greater than 30 inches may reduce crystal life and stability. Install the feedthrough using proper gaskets and vacuum grease if needed. The small electrical coax connector should be on the vacuum side of the installation.

### *Vacuum Feedthrough*

Caution



**Ensure that the water lines are clear of obstructions before operating the sensor above room temperature. A water flow rate of 0.2 to 0.3 gpm is adequate for most applications.**

## ELECTRICAL IN-VACUUM CABLE

The electrical cable from the sensor head to the vacuum feedthrough should be wrapped around the water lines using up all excess length in the process. Firmly tighten the connectors at both the sensor and feedthrough ends. The water lines and sensor cable should then be wrapped with clean tin foil or other shielding material to prevent evaporant build-up and also to aid cable cooling and mechanical stability.

Bakeable sensing heads are custom User designed sensor units. The electrical and water cooling lines are typically integral to the design of the unit. The units are generally made on a 2 3/4" ConFlat type flange and is installed as a one piece assembly. See Appendix B, Technical Drawings, for typical styles of bakeable sensing heads.

The sensor head must always be operated at "GROUND" potential and this connection is carried through the sensor feedthrough coaxial connectors and shields. The remote oscillator is attached to the vacuum feedthrough via the six-inch male / female coax cable. The long coax cable connects the remote oscillator to the display unit. This cable must be a coaxial 50 Ohm type and can be up to 500 feet in length.

For safety purposes a ground wire should always be installed between the vacuum vessel and earth ground. See Figure 3.2.

*Vacuum Electrical  
Connections*

*Bakeable Sensor*

# **SECTION 4**

*Calibration And Theory*



## Calibration and Theory

### Measurement Theory

The STM-100 / MF uses the resonant frequency of an exposed quartz crystal to sense the mass of deposited films attached to its surface. There is a known relationship between the mass of such a film and the measured frequency of the sensor crystal. Knowing the frequency change due to accumulated mass, film thickness is determined by the following equation:

$$A_f = \left[ \frac{(N_q \cdot D_q)}{(\pi \cdot D_f \cdot Z \cdot F_c)} \right] \cdot \text{ArcTan} \left[ Z \cdot \text{Tan} \left[ \frac{\pi \cdot (F_q - F_c)}{F_q} \right] \right] \quad (1) \quad (2)$$

Where The Terms Used In The Equation Are Defined As:

- A<sub>f</sub>** Film Thickness, In Angstroms (1Å=10<sup>-10</sup> Meters)  
**N<sub>q</sub>** Frequency Constant For At Cut Crystal, 1.668 X 10<sup>13</sup> Hz·Ång  
**D<sub>q</sub>** Density Of Quartz 2.648 gm/cm<sup>3</sup>  
**P** The Constant Pi, 3.14159265358979324  
**D<sub>f</sub>** Density Of Film Material In gm/cm<sup>3</sup>  
**Z** Z-Factor of material, is the square root of the ratio [(d<sub>q</sub>·u<sub>q</sub>)÷(d<sub>f</sub>·u<sub>f</sub>)]. D<sub>q</sub> and d<sub>f</sub> are the density and u<sub>q</sub> and u<sub>f</sub> are the shear moduli of quartz and the film, respectively. These values are available in several materials handbooks.  
**F<sub>q</sub>** Frequency of sensor crystal prior to depositing film material on it. This value is a manufacturing controlled constant.  
**F<sub>c</sub>** Frequency Of Loaded Sensor Crystal.

By measuring the period of approximately 1.2 million cycles of the sensor oscillator signal and using a stable vhf reference clock, an extremely accurate frequency value for f<sub>c</sub> is derived. Four times per second, a new value is determined and used to update the above equation. The mathematics is computed using IEEE double precision floating point format, ensuring the most accurate results obtainable from the exact equation, even over wide extremes of the Z-Factor and density parameters used in thin-film deposition. Use of the tangent and arctangent functions to compute the film thickness to the resolution of the floating point numeric format (56 bits of resolution) ensures maximum accuracy. Previous solutions incorporated approximations to Equation 1 or dealt strictly with the period type of measurement solution. The thickness zero function stores as a base or offset of the current sensor frequency and film thickness information, which is then continuously subtracted from the later updated readings, yielding a deposited film thickness value based on accumulated material since the latest zero function was performed.

Rate computation is based on the rate of change of these thickness readings, updated four times per second, then filtered for display. Also available from the instrument is the raw measured frequency of the sensor crystal.

### SECTION 4.1

#### Equation 1:

#### Measuring Period

#### Rate Computation

## Thickness Reading Calibration

### SECTION 4.2

#### Thickness

Instrument calibration is affected by three different parameters, material density, material Z-Factor, and tooling. Tooling is a deposition system geometry correction (location of sensor relative to substrates). Density and Z-Factor are material factors.

#### Density Determination

#### Density

Use of the material bulk density value will normally provide sufficient film thickness accuracy. If additional accuracy is required, the following procedure may be used:

Using a new sensor crystal (this eliminates Z-Factor errors) place a substrate adjacent to the sensor so that both sensor and substrate see the same evaporant stream. Set the instrument density to the bulk value of the material (see the Material Reference Table in section 4.3). Set the Z-Factor to 1.000 and the tooling factor to 100%. Deposit approximately 5000 angstroms of material on the sensor and substrate. After deposition remove the substrate and measure the film thickness with a profilometer or multiple beam interferometer. The correct density value may be determined by the formula:

$$\text{Density} \left( \frac{\text{Gm}}{\text{cc}} \right) = \frac{(\text{Density Parameter}) \bullet (\text{Reading})}{(\text{Measured Thickness})}$$

The calculated value may be checked by setting the STM-100 / MF density parameter to the calculated value and observing that the STM-100 / MF thickness display shows the corrected reading. Minor value adjustments can be made to make the measurements and calculations exactly equal.

#### Z-Factor Determination

#### Z-Factor

A list of Z-Factor values may be found in the material reference table in section 4.3. For other materials Z-Factor may be calculated by the following formula:

$$\text{Z - Factor} = \left[ \frac{D_q \bullet U_q}{\frac{D_f}{U_f}} \right]^{1/2}$$

**D<sub>q</sub>** = Density Of Quartz

**U<sub>q</sub>** = Shear Modulus Of Quartz

**D<sub>f</sub>** = Density Of Film

**U<sub>f</sub>** = Shear Modulus Of Film



The density and shear modulus values may be found in many material reference handbooks. Film Z-Factor values are typically very close to bulk Z-Factor values. High stress materials seem to have values slightly lower than expected. For a more exact solution make a calibration deposition similar to the density method. Use the calibrated density value, a Z-Factor of 1.000 and a tooling of 100%. Deposit a thick film using at least 50% of the sensor crystal life. Measure the substrate and then adjust the STM-100 / MF Z-Factor parameter until the correct thickness is displayed.

### Tooling Determination

Place a substrate in the normal holder location and deposit a film of approximately 5000 angstroms using either bulk or calibrated density and Z-Factor values. Make sure that when doing this calibration the tooling is set to 100%. Measure the substrate film thickness as in the density calibration method and determine the correct tooling factor value by the following formula:

$$\text{Tooling \%} = 100 \times \frac{(\text{Substrate Thickness})}{(\text{Displayed Thickness})}$$

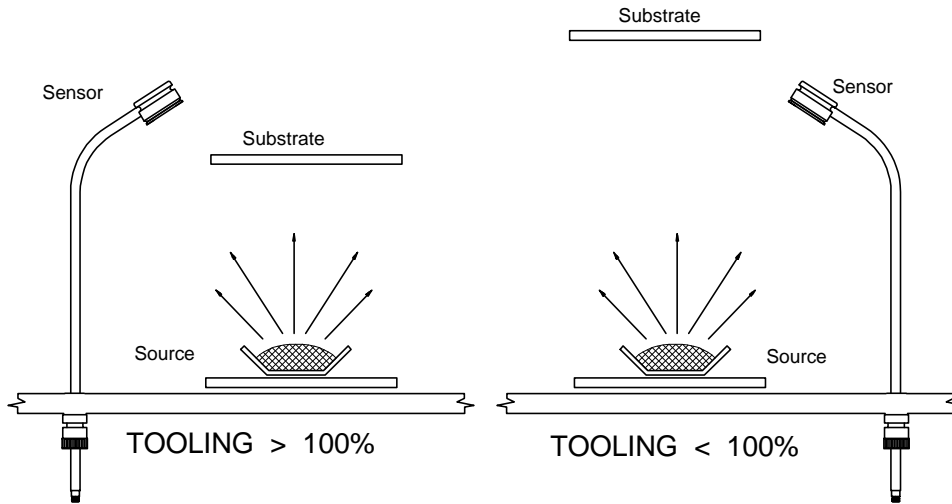

Figure 4.1: Typical Tooling Factors.

Generally tooling factors will follow the rule depicted by Figure 4.1.

**SECTION 4.3**

**Bulk Density and  
Z-Factor Values**

**Aluminum through  
Indium**

**Material Reference Table**

| Material               | Symbol                         | Bulk Density<br>Gm/cm <sup>3</sup> | Z-Factor |
|------------------------|--------------------------------|------------------------------------|----------|
| Aluminum               | Al                             | 2.73                               | 1.080    |
| Aluminum Oxide         | Al <sub>2</sub> O <sub>3</sub> | 3.97                               | -----    |
| Antimony               | Sb                             | 6.62                               | 0.768    |
| Arsenic                | As                             | 5.73                               | 0.966    |
| Barium                 | Ba                             | 3.50                               | 2.100    |
| Beryllium              | Be                             | 1.85                               | 0.543    |
| Bismuth                | Bi                             | 9.80                               | 0.790    |
| Bismuth Oxide          | Bi <sub>2</sub> O <sub>3</sub> | 8.90                               | -----    |
| Boron                  | B                              | 2.54                               | 0.389    |
| Cadmium                | Cd                             | 8.64                               | 0.682    |
| Cadmium Selenide       | CdSe                           | 5.81                               | -----    |
| Cadmium Sulfide        | CdS                            | 4.83                               | 1.020    |
| Cadmium Telluride      | CdTe                           | 5.85                               | 0.980    |
| Calcium                | Ca                             | 1.55                               | 2.620    |
| Calcium Fluoride       | CaF <sub>2</sub>               | 3.18                               | 0.775    |
| Carbon (Diamond)       | C                              | 3.52                               | 0.220    |
| Carbon (Graphite)      | C                              | 2.25                               | 3.260    |
| Cerium (III) Fluoride  | CeF <sub>3</sub>               | 6.16                               | -----    |
| Cerium (IV) Oxide      | CeO <sub>2</sub>               | 7.13                               | -----    |
| Chromium               | Cr                             | 7.20                               | 0.305    |
| Chromium (III) Oxide   | Cr <sub>2</sub> O <sub>3</sub> | 5.21                               | -----    |
| Cobalt                 | Co                             | 8.71                               | 0.343    |
| Copper                 | Cu                             | 8.93                               | 0.437    |
| Copper (I) Sulfide (A) | Cu <sub>2</sub> S (A)          | 5.60                               | 0.690    |
| Copper (I) Sulfide (B) | Cu <sub>2</sub> S (B)          | 5.80                               | 0.670    |
| Copper (III) Sulfide   | CuS                            | 4.60                               | 0.820    |
| Dysprosium             | Dy                             | 8.54                               | 0.600    |
| Erbium                 | Er                             | 9.05                               | 0.740    |
| Gadolinium             | Gd                             | 7.89                               | 0.670    |
| Gallium                | Ga                             | 5.93                               | 0.593    |
| Gallium Arsenide       | GaAs                           | 5.31                               | 1.590    |
| Germanium              | Ge                             | 5.35                               | 0.516    |
| Gold                   | Au                             | 19.3                               | 0.381    |
| Hafnium                | Hf                             | 13.1                               | 0.360    |
| Hafnium Oxide          | HfO <sub>2</sub>               | 9.63                               | -----    |
| Holmium                | Ho                             | 8.80                               | 0.580    |
| Indium                 | In                             | 7.30                               | 0.841    |

Table 4.1: Common Material Reference Table

| Material               | Symbol                         | Bulk Density<br>Gm/cm <sup>3</sup> | Z-Factor |
|------------------------|--------------------------------|------------------------------------|----------|
| Indium Intimonide      | InSb                           | 5.76                               | 0.769    |
| Indium Oxide           | In <sub>2</sub> O <sub>3</sub> | 7.18                               | -----    |
| Iridium                | Ir                             | 22.4                               | 0.129    |
| Iron                   | Fe                             | 7.86                               | 0.349    |
| Lanthanum              | La                             | 6.17                               | 0.920    |
| Lanthanum Fluoride     | LaF <sub>3</sub>               | 5.94                               | -----    |
| Lanthanum Oxide        | LaO <sub>3</sub>               | 6.51                               | -----    |
| Lead                   | Pb                             | 11.3                               | 1.130    |
| Lead Sulfide           | PbS                            | 7.50                               | 0.566    |
| Lithium                | Li                             | 0.53                               | 5.900    |
| Lithium Fluoride       | LiF                            | 2.64                               | 0.774    |
| Magnesium              | Mg                             | 1.74                               | 1.610    |
| Magnesium Fluoride     | MgF <sub>2</sub>               | 3.00                               | -----    |
| Magnesium Oxide        | MgO                            | 3.58                               | 0.411    |
| Manganese              | Mn                             | 7.20                               | 0.377    |
| Manganese (II) Sulfide | MnS                            | 3.99                               | 0.940    |
| Mercury                | Hg                             | 13.46                              | 0.740    |
| Molybdenum             | Mo                             | 10.2                               | 0.257    |
| Neodymium Fluoride     | NdF <sub>3</sub>               | 6.506                              | -----    |
| Neodymium Oxide        | Nd <sub>2</sub> O <sub>3</sub> | 7.24                               | -----    |
| Nickel                 | Ni                             | 8.91                               | 0.331    |
| Niobium                | Nb                             | 8.57                               | 0.493    |
| Niobium (V) Oxide      | Nb <sub>2</sub> O <sub>5</sub> | 4.47                               | -----    |
| Palladium              | Pd                             | 12.0                               | 0.357    |
| Platinum               | Pt                             | 21.4                               | 0.245    |
| Potassium Chloride     | KCl                            | 1.98                               | 2.050    |
| Rhenium                | Re                             | 21.04                              | 0.150    |
| Rhodium                | Rh                             | 12.41                              | 0.210    |
| Rubidium               | Rb                             | 1.53                               | 2.540    |
| Samarium               | Sm                             | 7.54                               | 0.890    |
| Scandium               | Sc                             | 3.00                               | 0.910    |
| Selenium               | Se                             | 4.82                               | 0.864    |
| Silicon                | Si                             | 2.32                               | 0.712    |
| Silicon (II) Oxide     | SiO                            | 2.13                               | 0.870    |
| Silicon Dioxide        | SiO <sub>2</sub>               | 2.20                               | 1.070    |
| Silver                 | Ag                             | 10.5                               | 0.529    |
| Silver Bromide         | AgBr                           | 6.47                               | 1.180    |
| Silver Chloride        | AgCl                           | 5.56                               | 1.320    |
| Sodium                 | Na                             | 0.97                               | 4.800    |
| Sodium Chloride        | NaCl                           | 2.17                               | 1.570    |
| Sulfur                 | S                              | 2.07                               | 2.290    |
| Tantalum               | Ta                             | 16.6                               | 0.262    |
| Tantalum (IV) Oxide    | Ta <sub>2</sub> O <sub>5</sub> | 8.20                               | 0.300    |

*Indium Intimonide  
through Tantalum*

Table 4.1: Common Material Reference Table, Continued

*Tellurium through  
Zirconium Oxide*

| Material              | Symbol                        | Bulk Density<br>Gm/cm <sup>3</sup> | Z-Factor |
|-----------------------|-------------------------------|------------------------------------|----------|
| Tellurium             | Te                            | 6.25                               | 0.900    |
| Terbium               | Tb                            | 8.27                               | 0.660    |
| Thallium              | Tl                            | 11.85                              | 1.550    |
| Thorium (IV) Fluoride | ThF <sub>4</sub>              | 6.32                               | -----    |
| Tin                   | Sn                            | 7.30                               | 0.724    |
| Titanium              | Ti                            | 4.50                               | 0.628    |
| Titanium (IV) Oxide   | TiO <sub>2</sub>              | 4.26                               | 0.400    |
| Titanium Oxide        | TiO                           | 4.90                               | -----    |
| Tungsten              | W                             | 19.3                               | 0.163    |
| Tungsten Carbide      | WC                            | 15.6                               | 0.151    |
| Uranium               | U                             | 18.7                               | 0.238    |
| Vanadium              | V                             | 5.96                               | 0.530    |
| Ytterbium             | Yb                            | 6.98                               | 1.130    |
| Yttrium               | Y                             | 4.34                               | 0.835    |
| Yttrium Oxide         | Y <sub>2</sub> O <sub>3</sub> | 5.01                               | -----    |
| Zinc                  | Zn                            | 7.04                               | 0.514    |
| Zinc Oxide            | ZnO                           | 5.61                               | 0.556    |
| Zinc Selenide         | ZnSe                          | 5.26                               | 0.722    |
| Zinc Sulfide          | ZnS                           | 4.09                               | 0.775    |
| Zirconium             | Zr                            | 6.51                               | 0.600    |
| Zirconium Oxide       | ZrO <sub>2</sub>              | 5.6                                | -----    |

Table 4.1: Common Material Reference Table, Continued

# **SECTION 5**

*Computer Interfacing*



## COMPUTER INTERFACING

The STM-100 / MF can be connected to a computer in a variety of ways. An RS-232 interface is standard, and either an IEEE or BITBUS interface can be added as an option. There is room for only 1 optional communications card. If you purchase a communications option and need to install it, see Section 3.8. For the RS-232 interface, either a SECS-II or standard Sycon protocol can be selected. This section will describe the hardware with each interface, and give an example of how to interface to an IBM-PC.

### RS-232 INTERFACE

RS-232 is an electrical specification for the transmission of data in a serial format. What this means is that the mechanism for transmitting data is defined by RS-232. The particular set of commands is defined by each vendor as they see fit. There is **no** computer program that will communicate with **all** RS-232 devices.

Different sets of commands and miscellaneous overhead must be handled differently. An example would be as if you were to call someone in a foreign country. Just because you can establish the link (the telephone) does not mean that you can communicate. Both parties must speak the same language. For this reason the SEMI institute has devised a protocol that allows different vendors of semiconductor processing equipment to "talk" RS-232 in a consistent manner. Unfortunately, because of the wide variety of situations that SECS-II will handle, it is a complicated protocol. The SECS-II protocol provided in each Sycon instrument is a sub-set of the full implementation, thus it is simpler and easier to install than the full implementation of SECS-II. It is selected by setting the CONFIGURATION dip switch on the back of the instrument. This is shown in Table 5.1.

### BAUD RATES and CABLING

No matter what protocol you are using, the first order of business is to get the STM-100 / MF connected to your computer and set up the baud rates. Figures 5.1a and 5.1b shows how to connect to an IBM-AT and IBM-PC. Note that the connectors are different for each type of computer.

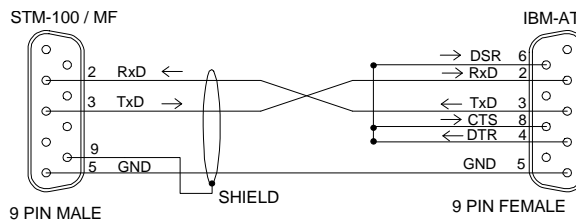

Figure 5.1: Cable Connection From STM-100 / MF to IBM-AT.

### SECTION 5.1

#### RS-232 Description

## Making an RS-232 Cable

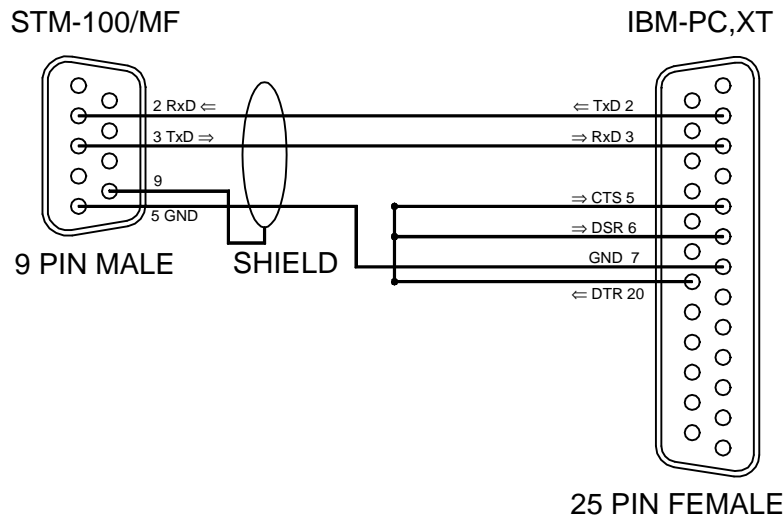

Figure 5.2: Connections for STM-100 / MF to PC Compatible Computers.

After the proper cable is made, make sure the baud rate of the computer and STM-100 / MF are the same. By setting two of the dip switches on the CONFIGURATION set of switches, you can set one of four baud rates as shown in Table 5.1.

### Communication Demo Disk

The diskette included with this manual contains demonstration software that will verify the communications connection between a MSDOS based computer and the STM-100 / MF. The program STMCKOUT.EXE communicates with the STM via RS232 and will exercise the communication sub system. For more information of other programs on the diskette refer to Appendix A. Follow the directions in the next paragraphs to set up the STM for serial communications.

### Setting Baud Rates

| SW6 | SW7 | BAUD |
|-----|-----|------|
| OFF | OFF | 300  |
| OFF | ON  | 1200 |
| ON  | OFF | 2400 |
| ON  | ON  | 9600 |

Table 5.1: Baud Rate Configuration Table.

Make sure that the baud rate on your computer is set to the same baud rate. The STM-100 / MF is shipped from the factory set at 9600 baud. To set an IBM-PC to the same baud rate, type in:

```
mode com1:9600,8,n,1 <Enter>
```

This will set the IBM for 9600 baud, 8 data bits, no parity, and 1 stop bit on its COM1 port. It is important to use 8 data bits because the communication protocols use all 8 of them.



## Sycon Protocol

The STM-100 / MF does not initiate any messages on its own. It responds only when "spoken" to. In order for error-free communications to occur, several safeguards are built in for checking data integrity. The general format for sending and receiving commands is:

### **STX (Data Length) (Data(Data..Data)) (Checksum)**

The STX character 0x02 (hex 02) indicates a start of message sequence. The STM-100 / MF uses this as a synchronization point. It just sits in a loop waiting for the STX character. If a different character is received, it is discarded. When the STX character is received, the STM looks at the rest of the characters in the command.

The data length is a character from 'SOH' (1 decimal) through 'LF' (10 decimal) and indicates the number of data characters in the message. The data is defined in the protocol below. The STM-100 / MF uses this number to determine where the end of the command is. If there is a mismatch between this number and the actual number of data characters in the message, two things can happen. If the data length number is low, the STM-100 / MF will terminate the command prematurely. The checksum will not match and an error will be recognized by the STM-100 / MF. It will not respond in any way.

If the data length number is high, the STM-100 / MF will be waiting for more characters than actually contained in the message. In order to recover from either kind of error, the **host** computer must have a time-out / retry capability built into the software.

The checksum is the sum (modulo 256) of only the data bytes. If this does not match the actual checksum of the data, an error message is recognized by the STM-100 / MF. It will not respond to the command. Refer to Figure 5.2 is a BASIC program that will run on an IBM-PC. It prompts you for a command to send to the STM-100 / MF and will print the response on the display. It is written in BASICA program, but will also run under Microsoft GWBASIC.

## **SECTION 5.2**

### **Message Format**

### Basic Driver Routine

```
4 REM SYCON STM-100 / MF COMMUNICATIONS DEMO ROUTINE. 6/12/1987 S. Bender
5 REM Sycon Instruments Inc. E. Syracuse, NY 13057
6 REM ***
8 REM Establish communications parameters and open as file #1.
10 OPEN "COM1:9600,N,8,1,CS,CD" AS #1
29 REM Get console user input to be sent to STM as a command.
30 INPUT "ENTER MESSAGE TO SEND";MSG$
34 REM Enter stop at prompt to exit program.
35 IF (MSG$="stop" OR MSG$="STOP") THEN 1000
39 REM Send message and get reply, or else some kind of error.
40 GOSUB 500
50 PRINT RPLY$
54 REM For debug purposes, show returned reply in hex codes too.
55 PRINT "HEX DATA IS {";
60 FOR CNT=1 TO LEN(RPLY$)
70 PRINT USING "\ " ;HEX$(ASC(MID$(RPLY$,CNT,1)));
75 IF CNT <> LEN(RPLY$) THEN PRINT " ";
80 NEXT CNT
90 PRINT "}"
99 REM Loop until break or user exit.
100 GOTO 30
101 REM ***** end of main program body *****
102 REM *****
103 REM **** start of msg/reply driver subroutine ****
499 REM initialize variables.
500 OUTCNT=LEN(MSG$):CKSUM=0
509 REM Compute outgoing message check sum.
510 FOR INDX= 1 TO OUTCNT:CKSUM=CKSUM+ASC(MID$(MSG$,INDX,1)):NEXT INDX
519 REM Send msg to STM, ASCII stx, count, and checksum.
520 PRINT#1,CHR$(2)+CHR$(OUTCNT)+MSG$+CHR$(CKSUM AND 255);
529 REM Get returned chars from STM-100 / MF and check for ASCII stx.
530 GOSUB 600:IF CHAR$ <> CHR$(2) THEN 520
539 REM Got ASCII stx, next data is length in binary, get it.
540 GOSUB 600:INCNT=ASC(CHAR$)
544 REM init variables for receiving incoming reply.
545 CKSUM=0:RPLY$=""
549 REM Loop inputting the remote reply message.
550 FOR INDX=1 TO INCNT
560 GOSUB 600:RPLY$=RPLY$+CHAR$:CKSUM=CKSUM+ASC(CHAR$)
565 NEXT INDX
569 REM Get final data, the checksum.
570 GOSUB 600
579 REM Check for valid checksum and data integrity.
580 IF (ASC(CHAR$))<>(CKSUM AND 255) THEN PRINT "BAD REPLY CHECKSUM"
590 RETURN
591 REM ***** End of msg/reply driver subroutine *****
592 REM *****
593 REM ** Start of receive a char from COM1 subroutine **
600 ON TIMER(3) GOSUB 620 : TIMER ON
610 IF LOC(1)<1 THEN 610 ELSE TIMER OFF : CHAR$=INPUT$(1,#1) : RETURN
620 TIMER OFF : PRINT "RECEIVE TIMEOUT" : CLOSE #1 : RETURN 10
621 REM **** End of receive a char from COM1 subroutine **
1000 PRINT:PRINT "PROGRAM TERMINATED BY USER":PRINT
```

Figure 5.3: BASIC Driver Routine.

## SECS-II Protocol

By setting switch number 5 (on the configuration DIP switches) to the ON position, the protocol for the RS-232 interface will be SECS-II. The SECS-II protocol requires that each communicating mode be assigned a unique station address. This is similar in concept to the LISTEN and TALK addresses used by IEEE-488. Although the RS-232 link used by the SECS-II standard is point to point and does not require station addressing for message routing, station addressing is used to allow for a "networked" approach to information transfer. This requires the address switches 8 through 12 be set and known by the host software. If either the IEEE-488 or BITBUS option is installed, the same address switches are used for it. Select an address that is compatible with both of these interfaces.

The SECS-II protocol has defined within it several parameters. The STM-100 / MF fixes these parameters to the following definitions:

T1, T2, T3 fixed at approximately 3 seconds  
RTY retry count fixed at 3  
M/S set to Master in the STM-100 / MF

For all other aspects of the SECS implementation, refer to SEMI publications E4-80 (SECS-I) and E5-85 (SECS-II).

The SECS-II standard (ES-85 Section 6.2) defines a standard form for SECS-II-compatible equipment manufacturers to use when describing the exact compliance of their equipment. The specific information that is required is detailed below.

- |  |   |
|--|---|
| a) Manufacturer and Product number           | Sycon Instruments, Inc.<br>STM-100 / MF   |
| b) General Description of Equipment Function | Thickness/Rate deposition<br>monitor using quartz crystal<br>technology                       |
| c) Intended Function of Interface            | To allow for queries of unit<br>status and data, and to alter<br>and control status as needed |
| d) Software Revision Code                    | This software responds to<br>SECS S1,F1 as version B2   |
| e) Changes from Previous Versions:           | This is the original SECS<br>compatible version   |

### **SECTION 5.3**

#### **SECS-II Addressing**

#### **SECS-II Protocol**

#### **Documentation Requirements**

#### **General Information**

### Message Summary

The following is a list of messages received and understood by the STM-100 / MF.

| Message Recd.       | Description                              | Reply Sent         | Desc                 |
|---------------------|--|--------------------|----------------------|
| S1 ,F1,<br>S64, F65 | Are you there request<br>STM comm packet | S1, F2<br>S64, F66 | On Line<br>STM Resp. |

### SECS-II Messages

The STM-100 / MF comm packet and response is contained under the category of COMMANDS (Section 5.5). Note that all commands and responses are in ASCII form.

The following is a list of commands that are sent by the STM-100 / MF caused by an error condition in the protocol.

| Message | Error                         | Cause  |
|---------|-------------------------------|--|
| F9, F1  | Unrecognized Device ID error. | SECS header has device ID which does not correspond to that set by internal DIP switch.                |
| S9, F3  | Unrecognized stream code.     | SECS header contains stream ID not understood by STM-100 / MF.   |
| S9, F5  | Unrecognized function code.   | SECS header contains function ID not valid or understood in conjunction with the header's stream code. |
| S9, F7  | Illegal data                  | Format of data for valid stream / function not correct.  |
| S9, F11 | Data too long.                |  |

### Message Details

#### Message Details

- a) S1,F1: Structure: Header only. As per SECS E5.
- b) S1,F2: Structure: as per SECS E5. MDLN is 6 character ASCII "STM100". SOFTREV is 2 character ASCII numeric "B2". Future versions will be incremental in decimal radix (07,08,09,10,11,..).
- c) S9,F1: Structure: as per SECS E5.
- d) S9,F3: Structure: as per SECS E5.
- e) S9,F5: Structure: as per SECS E5.
- f) S9,F7: Structure: as per SECS E5.
- g) S9,F11: Structure: as per SECS E5.
- h) S64,F65: Define: SYCONQCMD SYCON protocol query/command ASCII message. Format is 20. ASCII data contents is any SYCON message as detailed in the following RS-232 specification.  
Structure: <SYCONQCMD>
- i) S64,F66: Define: SYCONRSP SYCON protocol response ASCII message. Format is 20. ASCII data contents is any SYCON response message as detailed in the following RS-232 specification.  
Structure: <SYCONRSP>

## IEEE-488 INTERFACE OPTION

### SECTION 5.4

This is a parallel interface that is compatible with many different types of electronic instrumentation. It is a multi-drop interface that allows one controller and many slaves. You will generally find that IEEE-488 is the easiest computer interface to get running. The only thing that you need to set is the device address. The address is set on the CONFIGURATION switch (numbers 8 through 12). Table 2.2 contains IEEE-488, SECS, and BITBUS address codes. Make sure that every device on the network has a different address. Figure 5.3 is a program that runs on an HP-85 computer. It allows you to type commands in and see the response. This program assumes the address of the STM-100 / MF is set to 0.

### COMMANDS

### SECTION 5.5

While there are 2 protocols for RS-232, one for IEEE-488, and another for BITBUS, the command set for all of these is the same. The only things that change are the prefix before the command and the suffix after. All commands and data are in printable ASCII form. Only the prefix and suffix characters that make up the protocol-dependent data are allowed to be non-printable. All commands are a single character. There can be modifying data associated with the command, but the command is a single character. Table 5.2 contains a list of all commands. Section 5.6 has a detailed description of each command

```
5      DISP "ENTER CMD, CR TO QUIT"
10     INPUT A$
12     GOSUB 20
14     GOTO 5
20     N=LEN(A$)
25     IF N=0 THEN GOTO 5
30     B$=VAL$(N)&"A"
40     OUTPUT 700 USING B$ ; A$
50     ENTER 700 ; A$
60     DISP A$
62     RETURN
65     DISP "DONE"
70     END
```

Figure 5.4: HP-85 IEEE-488 BASIC Driver Program.

### RESPONSE FORMAT

All commands received by the STM-100 / MF will return a response. The minimum response (not including protocol dependent characters) is a single ASCII character. This character indicates two things. First, the success or failure of the command which was sent. One of four result types is returned, to indicate success (AOK), illegal command token (not in Table 5.2), illegal data value (number out of range for command), and illegal modifier (something other than required ?,!, @, = sent after command token).

Second, the returned response character reports the power on reset status of the STM-100 / MF. Each of the four response codes (see below) is modified after a reset until the L command resets the power failure flag. In this way each response message informs the host as to the occurrence of an instrument reset since the last exchange. The reason this is done is so that in every communication exchange a power on reset can be detected and the correct exception processing be performed via host software, without special polling overhead.

| Message                | Power Lost | No Reset |
|------------------------|------------|----------|
| Message AOK            | B          | A        |
| Illegal Command        | G          | F        |
| Illegal Data Value     | I          | H        |
| Illegal Cmnd. Modifier | K          | J        |

**Command List For STM-100 / MF**

| Parameter | Example                  | Comment         |
|-----------|--------------------------|-----------------|
|           | <b>Sent</b>              | <b>Returned</b> |
| @         | None                     | @ STM100C5      |
| A         | [@,!,?]                  | A@              |
| B         | None                     | B               |
| C         | None                     | C               |
| D         | None                     | D               |
| E         | =[0.500 - 99.99],[?]     | E=1.23          |
| F         | =[0.100 - 9.999],[?]     | F?              |
| G         | =[0 - 9999999],[?]       | G=550           |
| H         | =[0 - 9999999],[?]       | H=10560         |
| I         | =[00:00 - 99:59],[?]     | I=15:30         |
| J         | =[10.0 - 399],[?]        | J = 80.1        |
| K         | [@,!,?]                  | K?              |
| L         | None                     | L               |
| M         | None                     | M               |
| O         | None                     | O               |
| P         | None                     | P               |
| Q         | None                     | Q               |
| R         | None                     | R               |
| S         | None                     | S               |
| T         | None                     | T               |
| U         | None                     | U               |
| V         | None                     | V               |
| W         | None                     | W               |
| X         | None                     | X               |
| Y         | None                     | Y               |
| Z         | None                     | Z               |
| a         | None                     | a               |
| b         | None                     | b               |
| c         | [@,!,?]                  | c?              |
| d         | None                     |                 |
| e         | Mask                     |                 |
| f         | None                     |                 |
| g         | None                     |                 |
| h         | None                     |                 |
| i         | [1-9,?]                  | i5              |
| j         | [1-9],[0.500 - 99.99][?] |                 |
| k         | [1-9],[0.100 - 99.99][?] |                 |
| l         | [1-9],[0 - 9999000][?]   |                 |
| m         | [1-9],[0 - 9999000][?]   |                 |
| n         | [1-9],[00:00 - 99:59][?] |                 |
| o         | [1-9],[10.0 - 399][?]    |                 |

Table 5.2: Communication Command Summary.

**DETAILED COMMAND DESCRIPTION**

**SECTION 5.6**

**Software Version Code**

|              |  |
|--------------|--|
| Command:     | @  |
| Parameter:   | None   |
| Description: | Returns a string indicating the product model number and the software revision level. The form is "STM100XY" where X is major (A,B,..) and Y is minor digits (0..9). |

---

Command: A  
Parameter: [@,!/?]  
Description: Turns the shutter relay on and off. A "@" will turn the shutter off and a "!" will turn it on. The indicator on the LCD will indicate the new state. A "?" will send back "@" or "!" as the current status.

---

***Shutter Relay Control***

---

Command: B  
Parameter: None  
Description: Zeros the timer and thickness. This duplicates the ZERO button on the front panel.

---

***Zero Thickness and Timer***

---

Command: C  
Parameter: None  
Description: Zeros only the thickness.

---

***Zero Thickness***

---

Command: D  
Parameter: None  
Description: Zeros only the timer.

---

***Zero Timer***

---

Command: E  
Parameter: =[0.500 .. 99.99] | [?]  
Description: Sets the density parameter of the currently selected film. If a "?" is sent as a parameter, the current density value is returned. The units are gm/cc.

---

***Set the Density Parameter***

---

Command: F  
Parameter: =[0.100 .. 9.999] | [?]  
Description: Sets the material Z-Factor of the currently selected film. If a "?" is the parameter, the current Z-Factor is returned.

---

***Set the Z-Factor Parameter***

---

Command: G  
Parameter: =[0 .. 9999000] | [?]  
Description: Sets the end thickness of the currently selected film. While any resolution number can be programmed (up to 7 digits), the number that is accepted by the STM-100 / MF will be within the display range. This is limited to a total of 4 digits. The units are Angstroms.

---

***Set the End Thickness***

---

Command: H  
Parameter: =[0 .. 9999000] | [?]  
Description: Set the setpoint relay thickness limit of the currently selected film. See the description for the G command.

---

***Set the Setpoint Relay Thickness***

**Set the Timer Relay Parameter**

---

Command: I  
Parameter: =[00:00 .. 99:59] | [?]  
Description: Set the setpoint timer relay of the currently selected film. The format is "Minutes:Seconds". A "?" will return the current value.

---

**Set the Tooling Factor Parameter**

Command: J  
Parameter: =[10.0 .. 399] | [?]  
Description: Set the tooling factor parameter of the currently selected film. A "?" will return the current value. The units are in percent.

---

**Turn the Test Mode On/Off**

Command: K  
Parameter: [ @,!,? ]  
Description: Turns the test mode on and off. A "@" will turn the test mode off, a "!" will turn it on, and a "?" will return the current status.

---

**Acknowledge the Status of Non-Volatile Memory**

Command: L  
Parameter: None  
Description: Acknowledges valid receipt of power on status and resets internal flags. See "a" command.

---

**Get the Crystal Fail Status**

Command: M  
Parameter: None  
Description: Returns the crystal fail status. If a "@" is returned, the crystal is good. A status of "!" indicates that the crystal has failed.

---

**Get the Status of the Setpoint Timer Relay**

Command: N  
Parameter: None  
Description: Returns the status of the setpoint timer relay. If a "@" is returned, the relay is open (time has not been reached). A status of "!" indicates that the relay is closed (time has been reached).

---

**Get the Status of the Setpoint Thickness Relay**

Command: O  
Parameter: None  
Description: Returns the status of the setpoint thickness relay. If a "@" is returned, the relay is open (thickness has not been reached). A status of "!" indicates that the relay is closed (time has been reached).

---



---

Command: P  
Parameter: None  
Description: Returns the status of the end thickness status. This is not tied to a relay, but to an annunciator. End Thickness closes the shutter and sets this status. A Zero Thickness command clears this status.

---

***Get the Status of the End Thickness Relay***

---

Command: Q  
Parameter: None  
Description: Returns the status of the 4 remote inputs. A code of @..O is sent back. The lower 4 bits of the character represent the 4 inputs. A 1 indicates that the input is at ground. A 0 indicates that the input is open or at a logic high. The following table defines the response bit weights with each input.

***Get the Remote Input Status***

| Input Name     | Active "ON" Weight |
|----------------|--------------------|
| Zero Timer     | 1                  |
| Zero Thickness | 2                  |
| Shutter Close  | 4                  |
| Shutter Open   | 8                  |

---

---

Command: R  
Parameter: None  
Description: Returns the status of the configuration switches. Because there are 12 switches, the returned value is between 0 and 4095. A value of 0 indicates that all switches are in the OFF (or down) position. Switch number 12 is theLS (1) bit, switch number 1 is the MS (2048) bit.

---

***Get the Configuration Switch Status***

---

Command: S  
Parameter: None  
Description: Returns the thickness value, in Angstroms. This number will always contain 7 digits with a leading space or minus sign. Leading zeros are not suppressed.

---

***Get the Thickness Value***

---

Command: T  
Parameter: None  
Description: Returns the rate value, in A/s. The format is a leading space or minus followed by NNN.N.

---

***Get the Rate Value***

---

Command: U  
Parameter: None  
Description: Returns the sensor frequency, in Hz. If the crystal has failed, the number is the last valid reading, or blanks if there was never a good reading.

---

***Get the Sensor Frequency***

---

**Get the Crystal Life Value**

Command: V  
Parameter: None  
Description: Returns the crystal life number, in percent. A new crystal will return a number around 100 percent. The format is 000.0 .. 100.0

---

**Get the Timer Value**

Command: W  
Parameter: None  
Description: Returns the timer value. The format is PMM:SS where P is "+", "-", or ">". The "+" indicates that the STM-100 / MF is counting up, the "-" that it is counting down, and ">" indicates that the timer has exceeded 99:59 (in the up direction).

---

**Get the Shutter Close Event Thickness Log**

Command: X  
Parameter: None  
Description: Returns the thickness value that existed at the last shutter close command event. This allows the reading to be captured when the shutter was closed. The format is the same as the S command.

---

**Get the Shutter close Time Log**

Command: Y  
Parameter: None  
Description: Returns the time between the last Zero Thickness event and the last Shutter Close event. **Not the same as the process timer.** The response uses the same format as the W command except there is no "-" countdown prefix.

---

**Get the Log Event Rate**

Command: Z  
Parameter: None  
Description: Returns the rate measured at the Shutter Close event. This is useful to hold the last rate reading before closing the shutter.

---

**Get the Power on Status**

Command: a  
Parameter: None  
Description: This command allows you to determine the occurrence of critical events (power loss, brownout, and non-volatile memory failure). A single character is returned between an "@" and a "G" (inclusive). The LS bit indicates (if 1) that a power up reset has occurred since the last L command. The next more significant bit is set by a brownout condition. The next bit indicates that the non-volatile memory was faulty when the STM100 attempted to load the parameter data for operation, and that default values are in use. The correct parameter information should be downloaded or entered manually before continuing. These three bits remain set until an L command acknowledges that the host computer is aware of the status, with two exceptions. The brownout status bit will be cleared by subsequent power failures (it is not stored in non-volatile memory). The parameter defaulted status bit will be cleared by either keyboard or computer interface re-programming of any internal parameter (density, z-factor, etc. ).

---

Command: b  
Parameter: none  
Description: This command forces the internal working parameter values to their default values ( Film = 1.0, Density = 1.0, Z-Factor = 1.0, End Thickness = 0, Setpoint Thickness = 0, Setpoint Timer = 00:00, and Tooling = 100%). This is primarily used for testing at Sycon, but can be used to set the instrument into a known configuration.

---

***Force Parameters to Their Default Values***

---

Command: c  
Parameter: [@, !, ?]  
Description: Set or query the Keyboard beeper mode. At power up the STM-100 / MF beeper sounds with each keypress. This can be toggled on and off via the keyboard (see Section 2.7) or via this command. The '@' modifier turns off the beeper, the '!' modifier turns it on, and the '?' requests the current beeper status, returned as either '!' (ON) or '@' (OFF).

---

***Turn the Key Board Beeper On/Off***

---

Command: d  
Description: System reset, computer requests a startup reset. Special Internal use.

---

***Internal Use Commands***

---

Command: e  
Argument: [XX]  
Description: Relay Over-ride, followed by 2 hex characters to substitute for current relay mask. Special Internal use.

---

---

Command: f  
Description: Reserved for Internal Use.

---

---

Command: g  
Description: Reserved for Internal Use.

---

---

Command: h  
Description: Reserved for Internal Use.

---

---

Command: i  
Argument: [=1 thru 9] | [?]  
Description: Set or query the current film. Example: command i=6, sets the current film to film 6.

---

***Multi-Film Film Number Selection***

**Multi-Film Density  
Parameter**

---

Command: j  
Argument: [1 thru 9] [=0.500 .. 99.99] | [?]  
Description: Sets the density parameter for the film specified in the first argument. If a "?" is sent as a parameter, the current density value is returned. Example: command j6=0.75 sets the density for film 6 to 0.750 gm/cc. The units are gm/cc.

---

**Multi-Film Z-Factor  
Parameter**

Command: k  
Argument:: [1 thru 9] [=0.100 .. 99.99] | [?]  
Description: Sets the material Z-Factor for the film specified in the first argument. If a "?" is the parameter, the current Z-Factor is returned. Example: command k5=0.5 sets the Z-Factor for film 5 to 0.5. Dimensionless number.

---

**Multi-Film End Thickness  
Parameter**

Command: l  
Argument: [1 thru 9] [=0 .. 9999000] | [?]  
Description: Sets the end thickness for the film specified in the first argument. While any resolution number can be programmed (up to 7 digits), the number that is accepted by the STM-100 / MF will be within the display range. This is limited to a total of 4 digits. The units are Angstroms.

---

**Multi-Film Set Point relay  
Thickness Parameter**

Command: m  
Argument: [1 thru 9] [=0 .. 9999000] | [?]  
Description: Sets the Set Point Relay thickness limit for the film specified in the first argument. See the description for the G command.

---

**Multi-Film Set Point Timer  
Relay Parameter**

Command: n  
Argument: [1 thru 9] [=00:00 .. 99:59] | [?]  
Description: Set the setpoint timer relay for the film specified in the first argument. The format is "Minutes: Seconds". A "?" will return the current value.

---

**Multi-Film Tooling Factor  
Parameter**

Command: o  
Argument: [1 thru 9] [=10.0 .. 399] | [?]  
Description: Set the tooling factor parameter for the film specified in the first argument. A "?" will return the current value. The units are in percent.

---

# **SECTION 6**

## *MAINTENANCE*



## MAINTENANCE

### Warnings

**SECTION 6.1**

**WARNING**

There are potentially lethal voltages present within the STM-100 / MF control unit with a line cord or a INPUT/OUTPUT cable attached. There are no operator serviceable components inside, do not remove any covers. Service should be performed by qualified personnel only. Disconnect all cables when removing or installing the STM-100 / MF instrument.

**CAUTION**

The STM-100 / MF and remote oscillator contain static sensitive components. Use adequate and appropriate precautions when attempting any service to these devices.

### CONTROL UNIT

| SYMPTOM  | CAUSE   | REMEDY                         |
|--|---|--------------------------------|
| 1. No Power LED  | a. Blown fuse   | Replace Fuse                   |
|  | b. Power switch off   | Switch power on                |
|  | c. Line cord loose or unplugged   | Tighten cord                   |
| 2. Constant crystal fail message   | a. Bad or severely oxidized sensor crystal  | New Crystal                    |
|  | b. Cable connections to oscillator or sensor missing or loose                       | Check Cables                   |
|  | c. Severe material buildup on edges of crystal holder causing a short at the sensor | Clean Sensor                   |
| 3. Large thickness jumps during deposition   | a. Defective crystal  | New Crystal                    |
|  | b. Crystal near end of life   | New Crystal                    |
|  | c. Particles or flakes on crystal seating surface                                   | Clean Sensor                   |
| 4. Crystal stops suddenly during deposition before reaching typical life expectancy. | a. Crystal being hit by small droplets of molten material source.                   | Move farther from source.      |
| 5. Thermal instability (large changes in thickness reading during source warm-up)    | a. Poor crystal seating   | Clean sensor                   |
|  | b. Poor or no water flow  | Correct flow                   |
|  | c. Excessive heating due to secondary electron formation in some sputtering systems | Increase water flow to sensor. |
| 6. Poor thickness reproducibility  | a. Poor source emission pattern   | Check source<br>move sensor    |
|  | b. Material adhesion to sensor poor   | New crystal                    |
| 7. Computer interface failure  | a. Baud rate wrong  | Correct cfgr                   |
|  | b. Format wrong   | Correct cfgr                   |
|  | c. Device address bad   | Correct cfgr                   |

## REPLACING A SENSOR CRYSTAL

### SECTION 6.2

The procedure for replacing the 6 MHz sensor crystal is the same for any type sensor head. Use caution in handling the crystals as they are very fragile. Chipped, cracked, dirty or stained crystals should not be used.

#### CAUTION

Crystals should never be handled by bare hands! Always use clean lab gloves and plastic tweezers to handle a crystal. This will avoid surface contamination of the crystal that might lead to poor electrical surface contact and possible poor film adhesion.

Dielectric films sometimes do not adhere strongly to the crystal surface and can cause erratic readings. Some dielectric will peel off the crystal when it is exposed to air. This is caused by gas absorption greatly changing the film stress characteristics. If peeling is observed, change to a new clean crystal.

Follow the procedures outlined below to change a sensor crystal.

1. Grip the sensor cap with a gloved hand and pull to unsnap the cap. The sensor crystal is captured in the cap. Place the sensor cap on a flat surface with the front face up and pop the crystal out by pressing gently down on the coated crystal surface with clean plastic tweezers or a similar type instrument. The crystal should come out easily. Take care not to damage the cap aperture opening to the crystal. Turn the cap over and place a new crystal with the fully coated surface towards the aperture opening (this side receives the evaporant stream) in the sensor cap. Use plastic tweezers to handle the new crystal.
2. *Gently* press the crystal into the finger spring holders using the plastic tweezers. This operation does not require much force. The crystal movement to become held by the finger springs is only about 25 thousandths of an inch. The sensor cap now holds the sensor crystal firmly in place. The cap may now be snapped into the sensor body.
3. Verify that the newly installed crystal is operating by looking at the STM-100 / MF "CRYSTAL FAIL" indicator legend. The flashing legend should not be present. If the "CRYSTAL FAIL" legend is present check for damaged cables, a cracked or broken crystal, or dirty contact surfaces in the sensor cap.



## Persistent Crystal Fail Indication

## SECTION 6.3

If you replaced the sensing crystal and the BAD CRYSTAL indication persists, the problem is most probably somewhere in the electrical connections. There exist approximately 12 mechanical electrical connections between the sensing crystal and the oscillator unit.

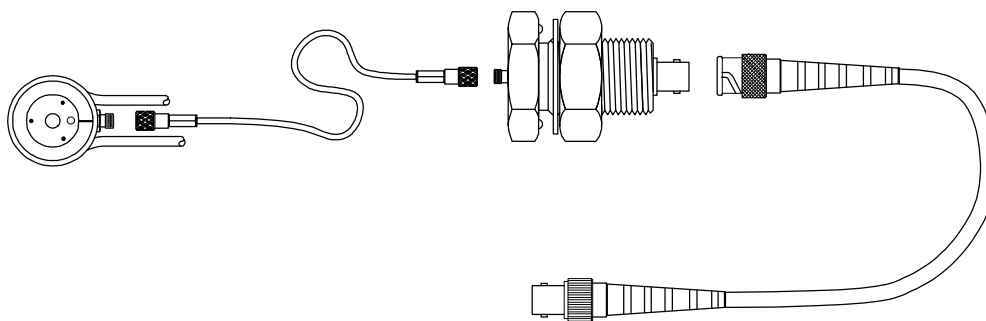

Figure 6.1: Sensor and Feed Through Connections.

Remote oscillators shipped after Sept. 1992 have a test feature to help isolate this type of problem, refer to Figure 6.2. A test push-button is provided on the oscillator. This button connects an internal test crystal located inside the remote oscillator in place of the normal sensing head. If the STM-100/MF and remote oscillator are functioning correctly the XTAL FAIL indicator will go away while this button is depressed. If this is observed while this button is depressed the problem of the persistent Bad Crystal indication has been isolated to be in the path between the remote oscillator and the sensing crystal. If the bad crystal indication continues while this button is depressed then the failure is either the programming of the sensor selection or in the electronics of the remote oscillator of the STM-100/MF unit itself. This push-button can be activated by inserting a small rod or wire, like an unbent paper clip in the 'push to test' hole and depressing the switch.

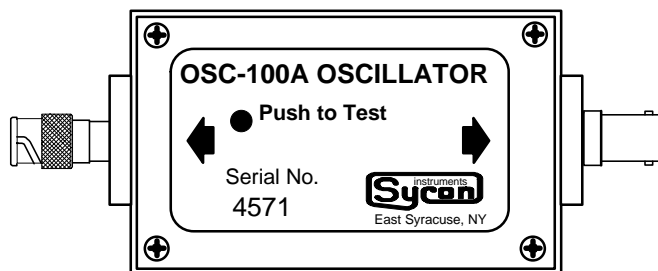

Figure 6.2: Test Oscillator OSC-100A.

The fastest and easiest way to check for good connectivity is to Ohm out the cable with a Ohm meter capable of reading  $0.10 \Omega$ . Remove the oscillator from the 6" BNC cable, and remove the sensor cover and sensing crystal from the sensing head. Measure the resistance from one of the center push spring contacts inside the sensor unit to the center conductor of the cable normally connected to the oscillator. The reading should be less than  $0.20 \Omega$ . The center conductor to the cable shield should be open (greater than  $30 M\Omega$ ) with respect to the outside ground shield of the cable. This check will verify all the connections from the sensor, the InVac cable, the vacuum feedthrough, and the BNC cable.

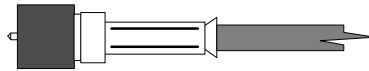

Figure 6.3: SM75, MicroDot<sup>®</sup> Connector.

If the reading from the continuity test is not as stated, disconnect one part of the chain and repeat the test. Repeat this last step until the bad connection is isolated. From experience, most often when a problem occurs it has been found that the SM75, MicroDot<sup>®</sup>, connectors on the InVac cable are not connected securely to the sensor or the feed through. If this is not true then the cable should be replaced. Also the center pin on the InVac cable can become damaged and not make contact with the mating connector, Refer to Figure 6.3. The center pin of the connector should extend slightly beyond the end of threaded ferrule. If the pin is damaged the cable should be replaced.

# **APPENDIX A**

*Communication Demo Disk*

## Communication Demo Disk

### Section A-1

Enclosed on this disk are several routines used to communicate with the STC-200 Controller and STM-100 Monitor. Source code is provided for the STCPARAM and RATE (STM-100) programs. The STCPARAM program will upload and download parameters to the STC-200. The RATE program will upload and download parameters and data to the Host computer. The programs are written in the language "C" and can be compiled using Borlands Turbo C compiler.

If you are new to programming and are looking for an inexpensive C compiler, we recommend purchasing Borlands. The list price is under \$100 and is available from many mail-order software houses at a discount. This provides a well integrated environment for writing C programs. If you already have another C compiler, there should be no problems in using it. If you do have any compiler problems, we will be happy to help you resolve them.

The two most common problems associated with RS-232 communication are baud rate settings and cable problems. Please make sure your RS-232 cable is wired up according to the drawings in the manual. The program SYCCOM.EXE is a simple way to ensure that the communication link is up and running. It operates from the COM1: port of your PC and uses interrupts. You type in a command and the response will appear on the screen. All of Sycon's products respond to the "@" command by telling you what the product is and what the version is.

The following lines are specific to the STC-200 Controller: There are several other programs on this disk that you may find useful. SCAN is a batch file that appends processes accounting information to a file. STCCKOUT is used to obtain various parameters from the STC. It is also used to upload and download I/O programs and film programs between the PC and the STC-200. The other executable files on this disk are used within the SCAN.BAT batch file.

TURBTERM is a program that converts your PC into a dumb terminal. It works with COM1: and is useful in debugging RS-232 problems. PC-COM is used to find out what the status of your communications ports in the PC are. It lists baud rate, data bits, parity, etc.

If you get stumped, give us a call and we will help you get up and running.

## STM-100 /MF Specific Programs

### STM-100 / MF Checkout Program

STMCKOUT.EXE Program to exercise the communication commands of the STM-100 / MF and display related hardware settings.

### STM-100 / MF Rate Program

RATE.EXE Program to gather rate information from the STM-100 / MF and present it in convenient forms.

Usage:

RATE.EXE [x]

Where [x] is the COM port ( 1 or 2) that the STM-100 is connected to.

This program is a text based routine and runs in one window on the screen.

#### The Rate Program Display Shows:

1. THICKNESS Thickness value from the unit in Angstroms.
2. TIMER Timer value from the unit.
3. TIME ON The time in minutes since the start button [ F1] was pressed.
4. TOTAL THICKNESS The total thickness since the start button was pressed. This corresponds to the **Time On** value.
5. RATES
  - a. INSTANT Angstrom per second. Corresponds to the Instantaneous rate that is read from the unit.
  - b. BY THE MINUTE Angstroms per minute. This is the average rate for the past minute of operation, converted to angstroms per minute.
  - c. BY THE HOUR Angstroms per hour. This is the average rate for the past hour of operation, converted to angstroms per hour.
  - d. TOTAL Angstroms per minute. This is the total rate calculated from the time the start button was pressed. Converted to Angstroms per minute.
6. CRYSTAL LIFE This is the crystal life, in percent, that remains for the current crystal.

7. USER PARAMETERS: Parameter values follow the same rules as the STM-100 / MF.

- a. Density. < F3 >
- b. Tooling < F4 >
- c. Zfactor < F5 >
- d. Timer Set Point < F6 >
- e. Thickness Set Point < F7 >
- f. End Thickness Set Point < F8 >
- g. Zero the Timer < F9 >
- h. Zero the Thickness < F10 >
- i. Data Save file <SHIFT F1>

Functions

- i.1. Prompts user for the name of the file and the time interval for saving the data, minimum 1 second.
- i.2. Toggles the Save feature.

8. DYNAMIC KEYS

- a. < F1 > Start / Stop
- b. < F2 > Open / Close The Shutter.
- c. ESC To Exit the Program.



# **APPENDIX B**

*Technical Drawings*





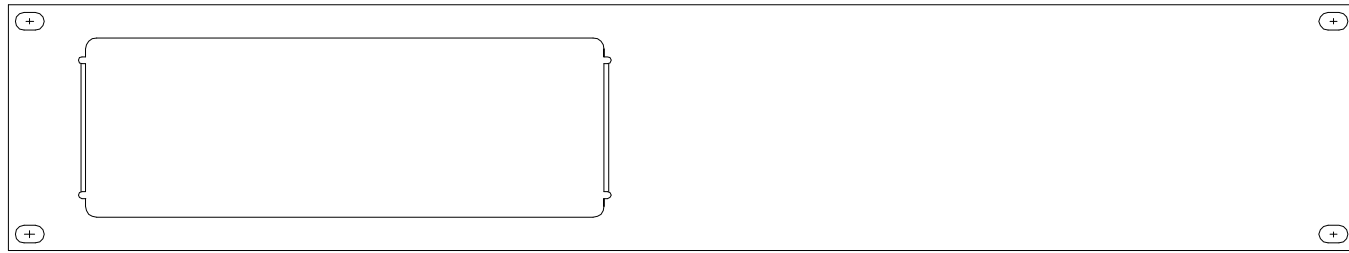
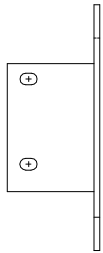

SINGLE RACK MOUNT

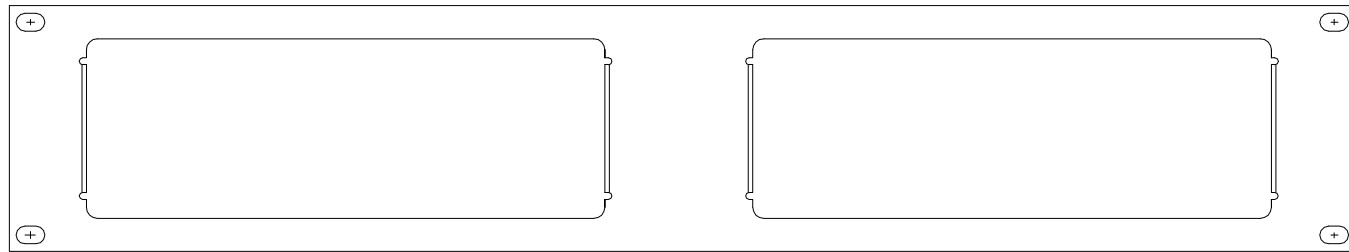
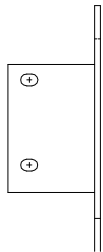

DUAL RACK MOUNT

Tolerance  
.XX= ±0.02  
.XXX= ±0.010  
ANGLES=



SCALE 1:1

19" STM RACK MOUNT

APPROVED BY:

SINGLE AND DUAL RACK MOUNTS

DR. BY: DJF

DATE: 03-11-1992

STM-RACK.DWG

REV

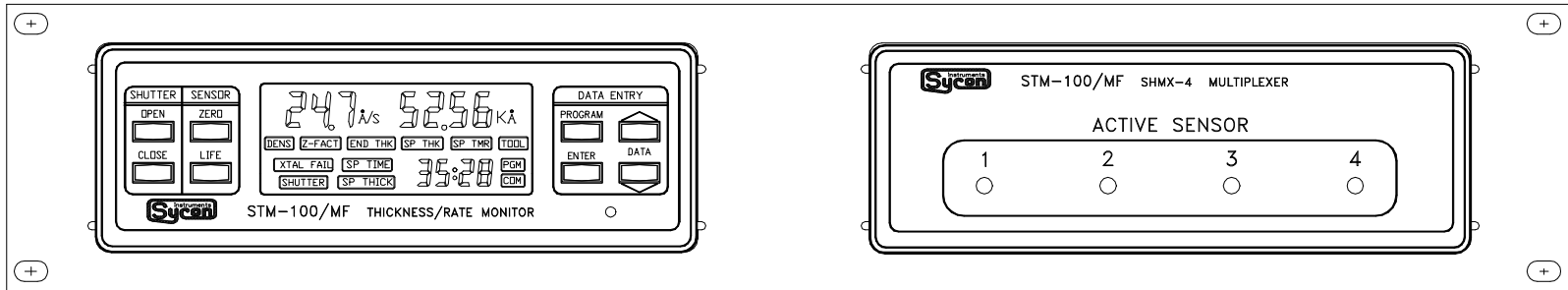

STM-100 / MF AND 4 CHANNEL  
MULTIPLEXER IN DUAL 19" RACK.

|  |             |   |
|--|-------------|---|
| Tolerance<br>.XX =<br>.XXX =<br>ANGLES = |             |  |
| SCALE                                    |             |   |
| APPROVED BY:                             | SIZE        | <b>SHMX-4 MULTIPLEXER</b><br>STM-100/MF 4 CHANNEL MULTIPLEXER                         |
| DR. BY: B. BRADY                         | C           |   |
| DATE: 04-14-1992                         | STM-MUX.DWG | REV. A  |

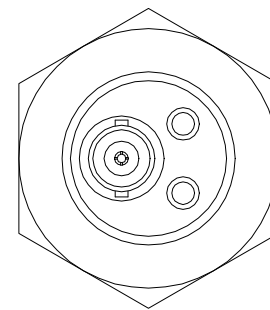
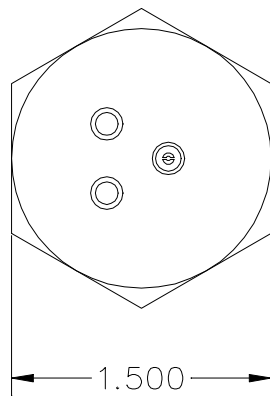
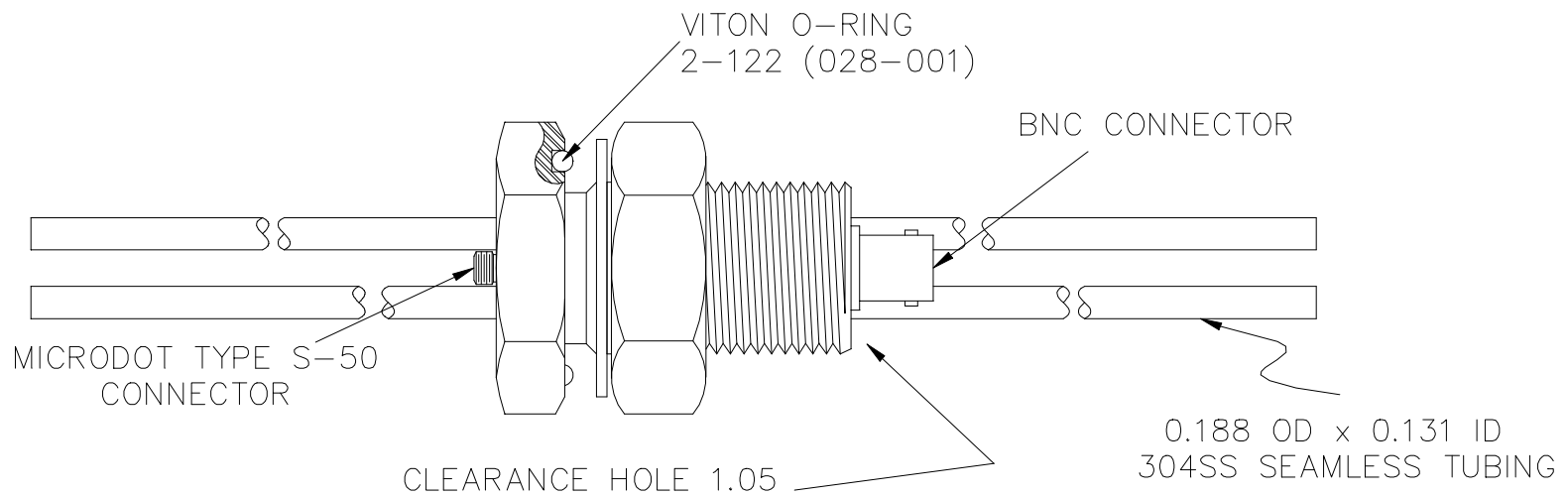

STANDARD 1" BOLT FEEDTHROUGH  
1 ELECTRICAL AND 2 FLUID PASSES

|   |                          |   |
|---|--------------------------|---|
| TOLERANCE<br>x.xx = ±0.01<br>x.xxx = ±0.005<br>ANGLES = ±1° |                          |  |
| SCALE 1:1   | 1" STD. BOLT FEEDTHROUGH |   |
| APPROVED BY: _____  | SIZE: A                  |   |
| DR. BY: _____   | DATE: 06-02-91           | 500-016 DOC. REV. A/A   |

∅0.265 (6 HOLES )  
ON 2.312 DIA. B.C.

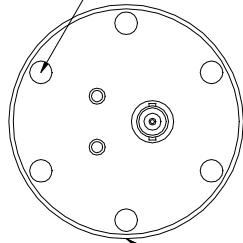

∅2 3/4" 'CONFLAT' TYPE FLANGE  
ROTATABLE

0.188" OD x 0.131" ID  
304SS SEAMLESS TUBING

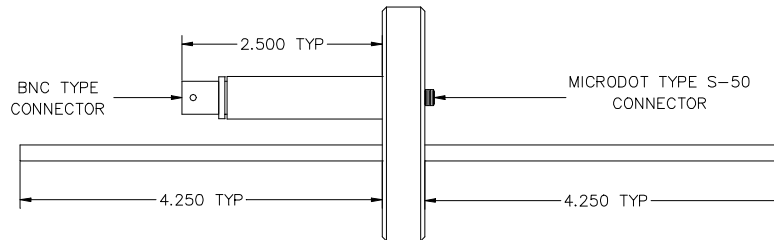
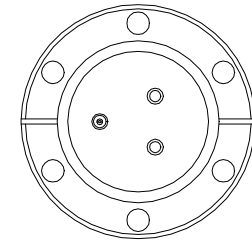
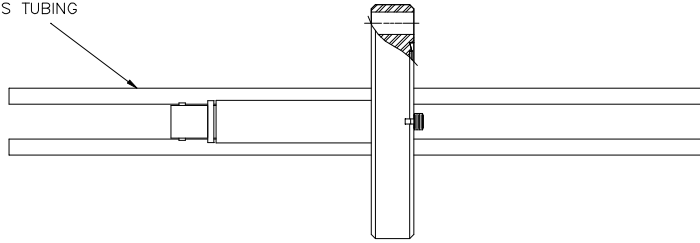

∅2 3/4" CONFLAT FEEDTHROUGH  
ALL WELDED CONSTRUCTION  
1 ELECTRICAL 2 FLUID PASSES

ORDER SENSOR PACKAGE 500-103 TO COMPLETE INSTALLATION

|   |  |
|---|--|
| TOLERANCE<br>X.XX = ±0.01<br>X.XXX = ±0.005<br>ANGLES = ±2° | <br><b>2 3/4" CONFLAT FEEDTHROUGH</b><br>1 ELECTRICAL / 2 FLUID |
| SCALE: NTS<br>APPROVED BY: C<br>DATE: 06-10-99              |  |
| DR. BY: M.METALLO   | 500-017 BIA  |

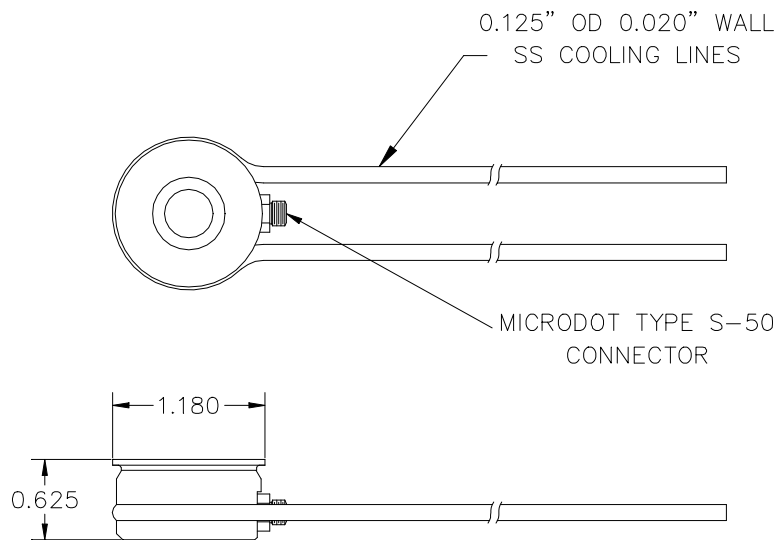

5 #4-40 TAP THRU  
4 EQUALLY SPACED  
ON  $\varnothing 0.731$  BC

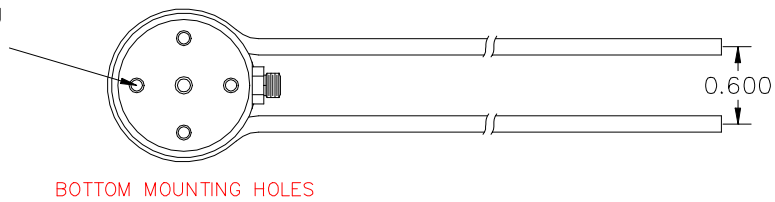

- LOW PROFILE SENSING HEAD
- SIDE ELECTRICAL CONNECTION ALLOWS BEST FIT IN MOST APPLICATIONS
  - SNAP TIGHT COVER
  - NO LOW TEMPERATURE MATERIALS USED. 304SS BODY & COVER
  - VACUUM BRAZED 1/8" WATER COOLING LINES
  - USES STANDARD DIAMETER .550" SENSING CRYSTAL

REPLACEMENT PARTS:

- 550-042 SENSOR COVER ASSEMBLY
- 024-002 COILED SNAP SPRING

|                        |                |
|------------------------|----------------|
| TOLERANCE              |                |
| X.XX                   | = $\pm 0.01$   |
| X.XXX                  | = $\pm 0.005$  |
| ANGLES = $\pm 1^\circ$ |                |
| SCALE: NTS             |                |
| APPROVED BY:           | SIZE: A        |
| DR. BY: M.METALLO      | DATE: 05-18-98 |

|   |  |
|---|--|
|  |  |
| <b>LOW PROFILE SENSING HEAD</b>   |  |
| 500-042   | <small>DOC. REV.</small><br><b>A/A</b> |

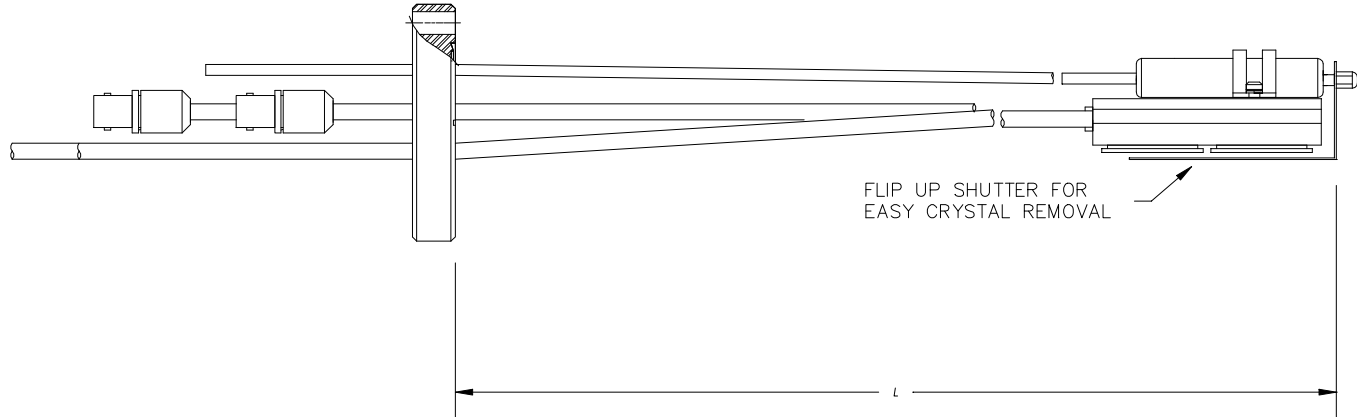
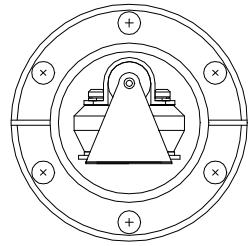

FLIP UP SHUTTER FOR EASY CRYSTAL REMOVAL

LENGTH FROM VACUUM SIDE OF FLANGE TO END OF SENSOR BLOCK TO BE SPECIFIED BY CUSTOMER. (3" MIN. TO 20" MAX.). SIMPLE BEND OPTION ALSO AVAILABLE.

BNC TYPE CONNECTOR

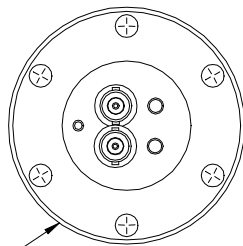

2 3/4" 'CONFLAT' TYPE FLANGE ROTATABLE

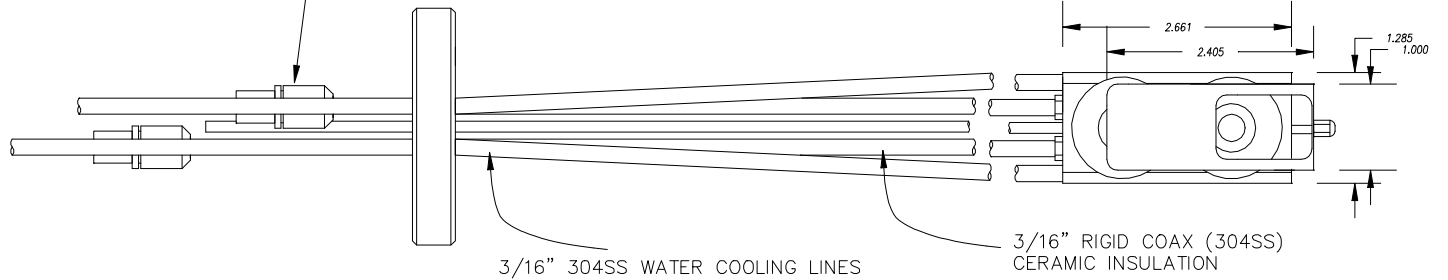

DUAL BAKEABLE SHUTTERED SENSOR HEAD ON 2 3/4" FLANGE.

BAKEABLE SENSING HEAD

- BAKEABLE TO 275°C
- Purge water lines prior to baking
- Length customer specified

|   |                |                       |
|---|----------------|-----------------------|
| TOLERANCE<br>X.XX = ±0.01<br>X.XXX = ±0.005<br>ANGLES = ±1° |                |                       |
| SCALE: NTS  |                |                       |
| APPROVED BY:  | SIZE: C        | DUAL BAKEABLE SHUTTER |
| DR. BY:   | DATE: 07-08-92 |                       |
|   |                | 500-050/LIAA          |

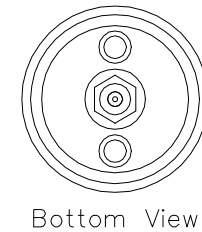
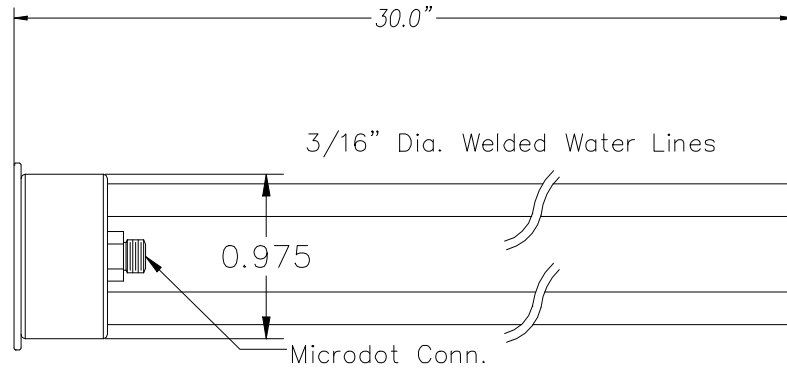
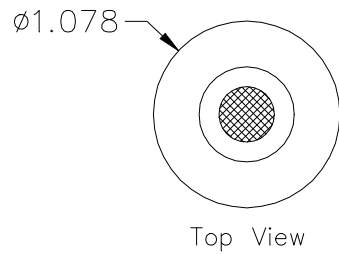

304 Stainless Steel  
 Crystal Holder  $\phi 1.078$ "  
 Sensor Body  $\phi .975$ "

RIGHT ANGLE SENSOR  
 -ELECTRICAL CONNECTION & WATER LINES EXIST TO BACK OF SENSOR

|   |         |   |
|---|---------|---|
| TOLERANCE<br>x.xx = $\pm 0.01$<br>x.xxx = $\pm 0.005$<br>ANGLES = $\pm 1^\circ$ |         |  |
| SCALE: NTS  |         |   |
| APPROVED BY:  | SIZE: A | RIGHT ANGLE SENSOR  |
| DR. BY: UNKNOWN   |         |   |
| DATE: 06-02-91  |         | 500-088   A/A   |



CLOSED, SENSOR 1 EXPOSED

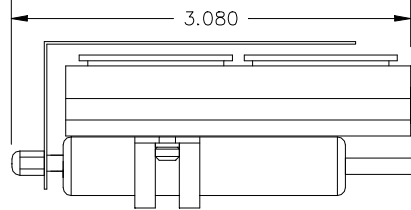

Pneumatic Actator  
50 PSI operating pressure

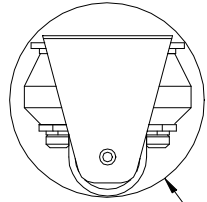
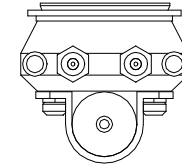

Ø1.500

OPEN, SENSOR 2 EXPOSED

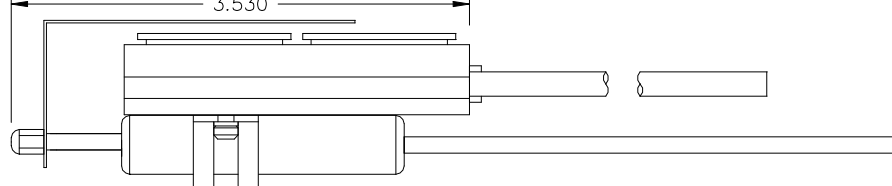

Mounting Bracket & Hardware

2.660  
CLOSED, SENSOR 1 EXPOSED

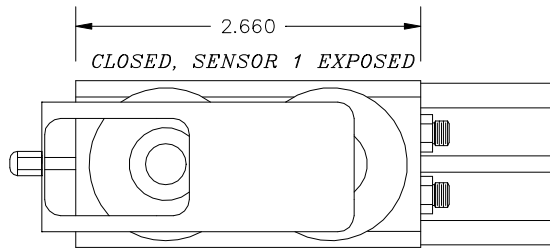

1/8" x 30" Air Tubulation

3/16" 30" Cooling Lines

0.695 1.271

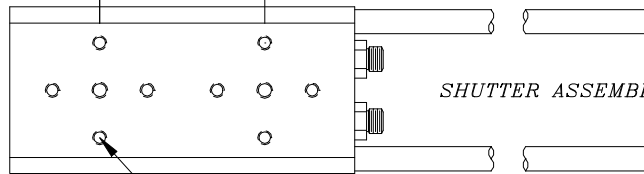

SHUTTER ASSEMBLY NOT SHOWN

MOUNTING HOLES  
#4-40 THRU ON Ø0.731 B.C.

TOLERANCE  
x.xx = ±0.01  
x.xxx = ±0.005  
ANGLES = ±1°

SCALE: NTS

APPROVED BY: SIZE: A

DR. BY: B.BRADY  
DATE: 11-07-95



DUAL SENSOR WITH SHUTTER

500-093

DOC. REV. AA

Ø0.265 (6 HOLES)  
ON Ø2.312 B.C.

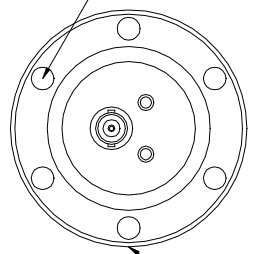

2 3/4" 'CONFLAT' TYPE FLANGE  
ROTATABLE

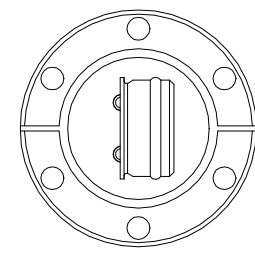
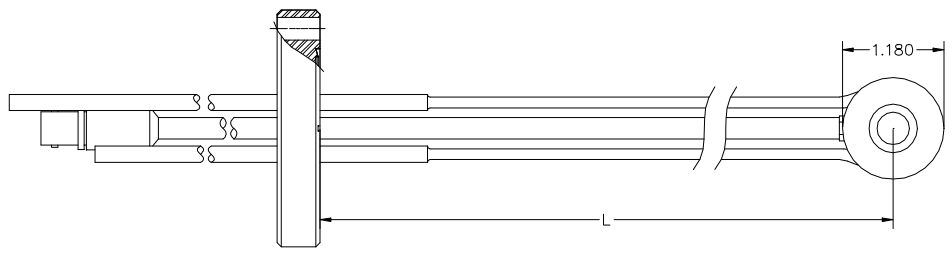

LENGTH FROM VACUUM SIDE OF FLANGE TO  
CENTER OF SENSING CRYSTAL TO BE SPECIFIED  
BY CUSTOMER. (3" MIN. TO 20" MAX)

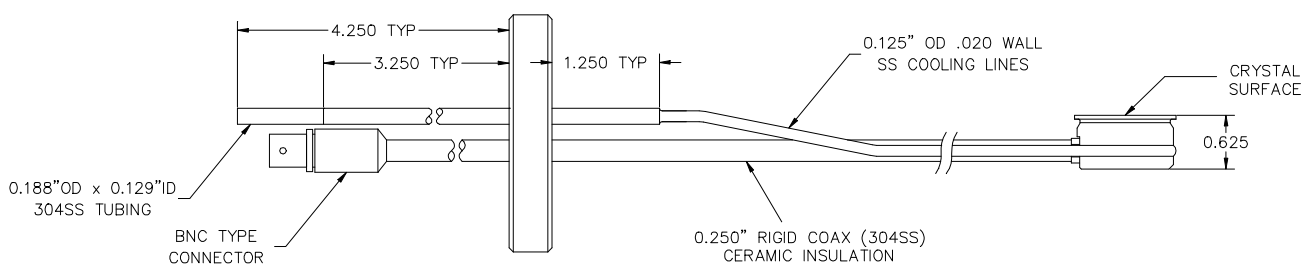

- BAKEABLE SENSING HEAD
- BAKEABLE TO 275°C
  - LENGTH CUSTOMER SPECIFIED
  - PURGE WATER LINES PRIOR TO BAKING

|   |                |                         |
|---|----------------|-------------------------|
| TOLERANCE<br>X.XX = ±0.01<br>X.XXX = ±0.005<br>ANGLES = ±1° |                |                         |
| SCALE: NTS  |                |                         |
| APPROVED BY:  | SIZE: C        | BAKEABLE SENSING HEAD   |
| DR. BY: M.METALLO   | DATE: 04-30-98 | DOC. REV: 501-009/L1A1A |

∅0.265 (6 HOLES )  
ON ∅2.312 B.C.

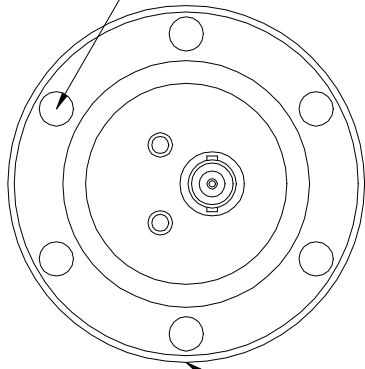

∅2 3/4" 'CONFLAT' TYPE FLANGE  
ROTATABLE

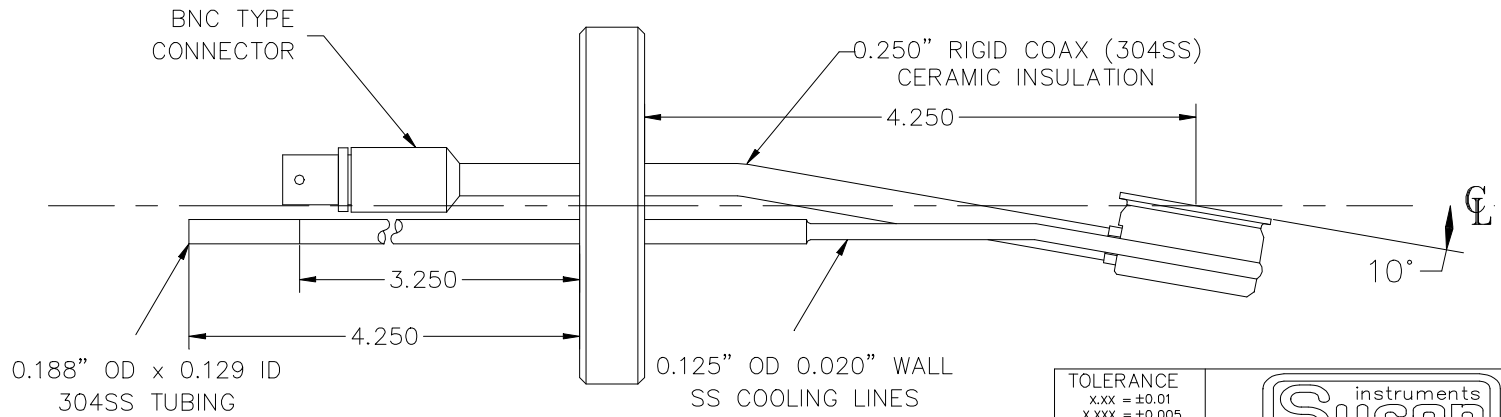
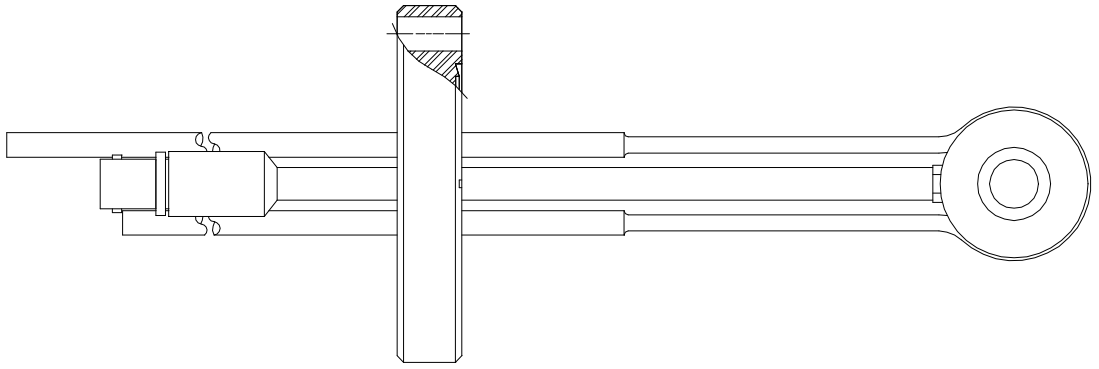

|                 |          |
|-----------------|----------|
| TOLERANCE       |          |
| x.xx            | = ±0.01  |
| x.xxx           | = ±0.005 |
| ANGLES = ±1°    |          |
| SCALE: NTS      |          |
| APPROVED BY: A  | SIZE: A  |
| DR. BY: B.BRADY |          |
| DATE: 11-10-95  |          |

**Sycon** instruments

**BAKEABLE SENSING HEAD**

SPECIAL SMALL VACUUM SYSTEM

501-031

DOC. REV. A/A

0.188" OD x 0.131" ID  
304SS SEAMLESS TUBING

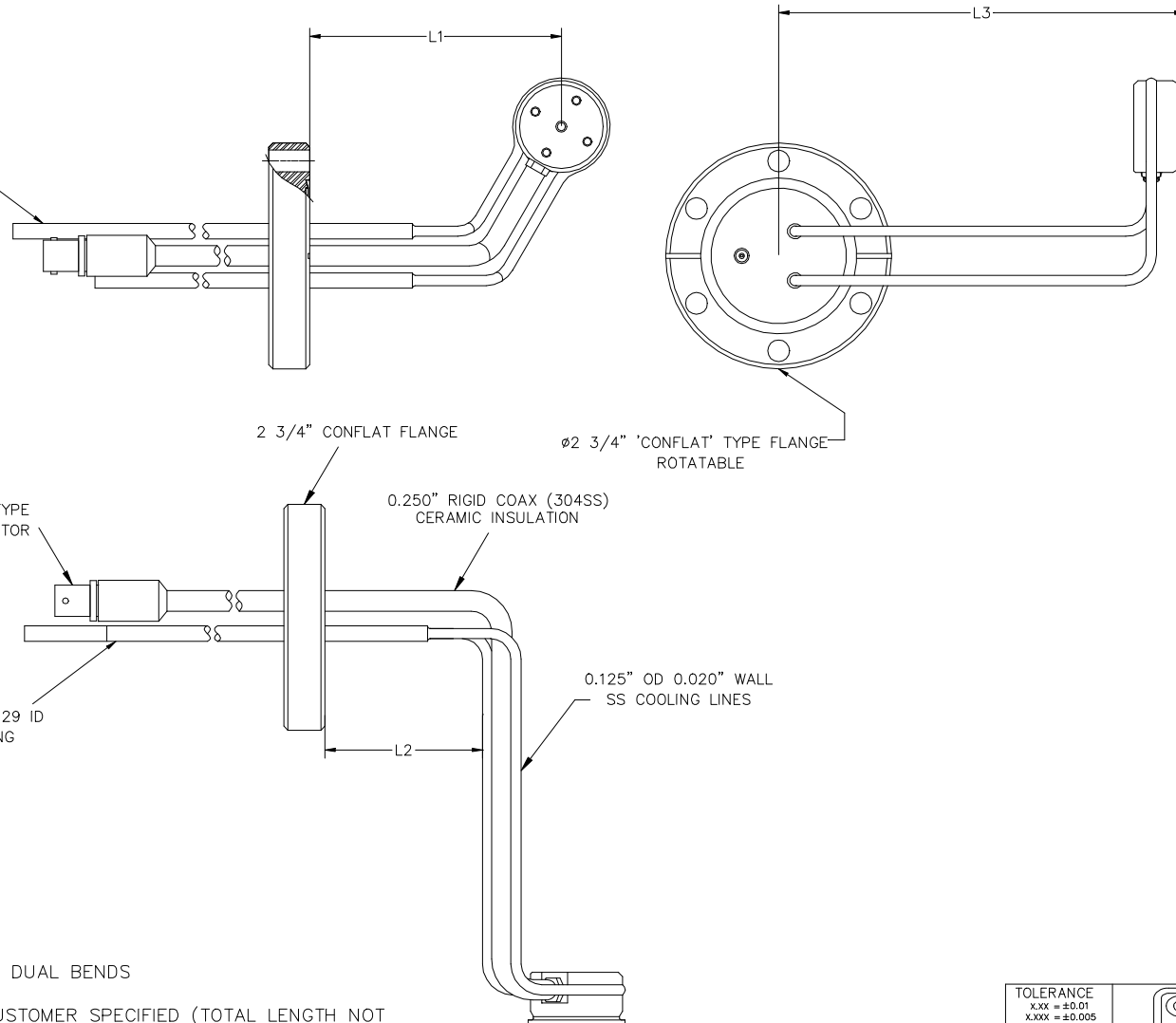

- BAKEABLE SENSING HEAD – DUAL BENDS  
 – BAKEABLE TO 275°C  
 – LENGTHS AND ANGLES CUSTOMER SPECIFIED (TOTAL LENGTH NOT TO EXCEED 20 INCHES)  
 – PURGE WATER LINES PRIOR TO BAKING

TOLERANCE  
 X.XX = ±0.01  
 X.XXX = ±0.005  
 ANGLES = ±1°  
 SCALE: NTS  
 APPROVED BY: SIZE: C  
 DR. BY: M.METALLO  
 DATE: 05-14-98



MODIFIED BAKEABLE SENSING HEAD  
 501-033  
 DOC. REV. IATA

Ø0.265 (6 HOLES )  
ON 2.312 DIA. B.C.

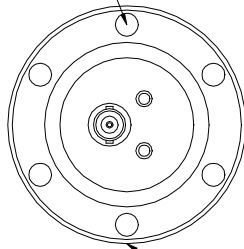

Ø2 3/4" 'CONFLAT' TYPE FLANGE  
ROTATABLE

2 3/4" CONFLAT FLANGE

0.125" OD 0.020" WALL  
SS COOLING LINES

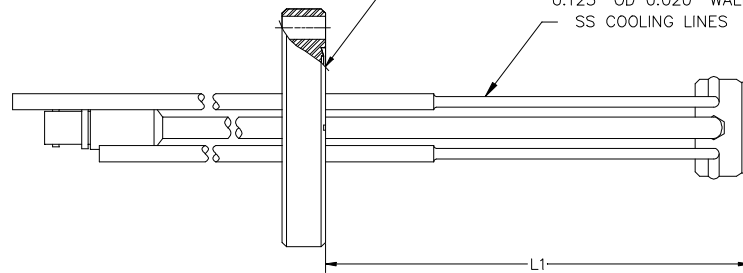

0.188" OD x 0.129 ID  
304SS TUBING

BNC TYPE  
CONNECTOR

0.250" RIGID COAX (304SS)  
CERAMIC INSULATION

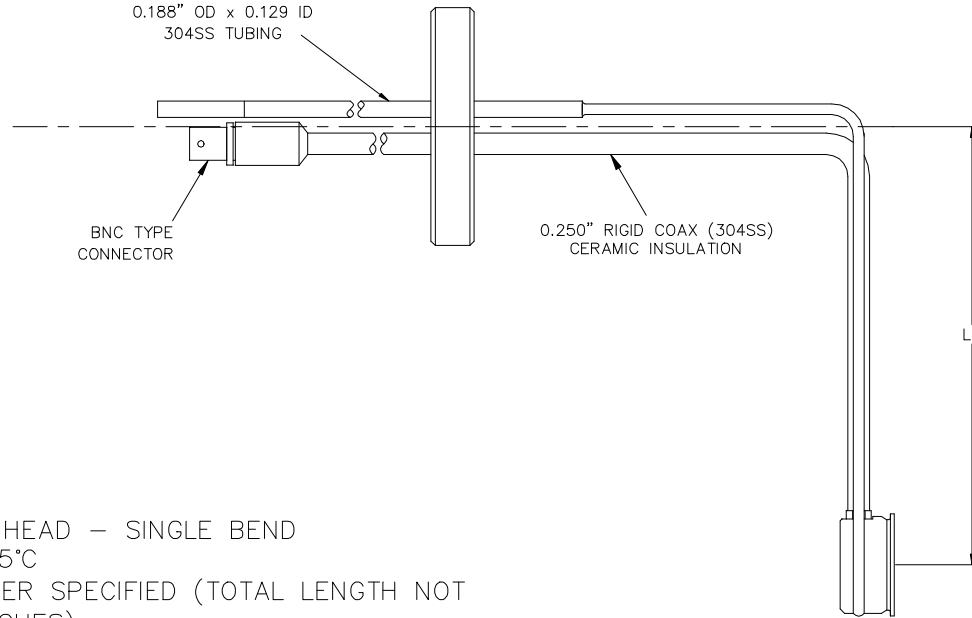

- BAKEABLE SENSING HEAD – SINGLE BEND
- BAKEABLE TO 275°C
  - LENGTHS CUSTOMER SPECIFIED (TOTAL LENGTH NOT TO EXCEED 20 INCHES)
  - PURGE WATER LINES PRIOR TO BAKING

|                   |                |
|-------------------|----------------|
| TOLERANCE         |                |
| X.XX              | ±0.01          |
| X.XXX             | ±0.005         |
| ANGLES = ±1°      |                |
| SCALE: NTS        |                |
| APPROVED BY:      | SIZE: C        |
| DR. BY: M.METALLO | DATE: 05-14-98 |



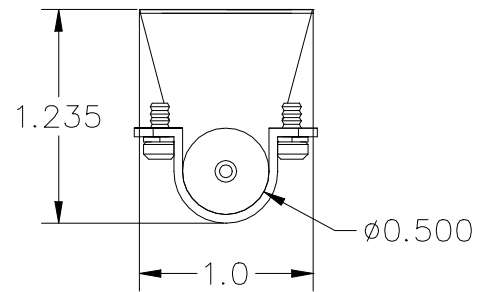
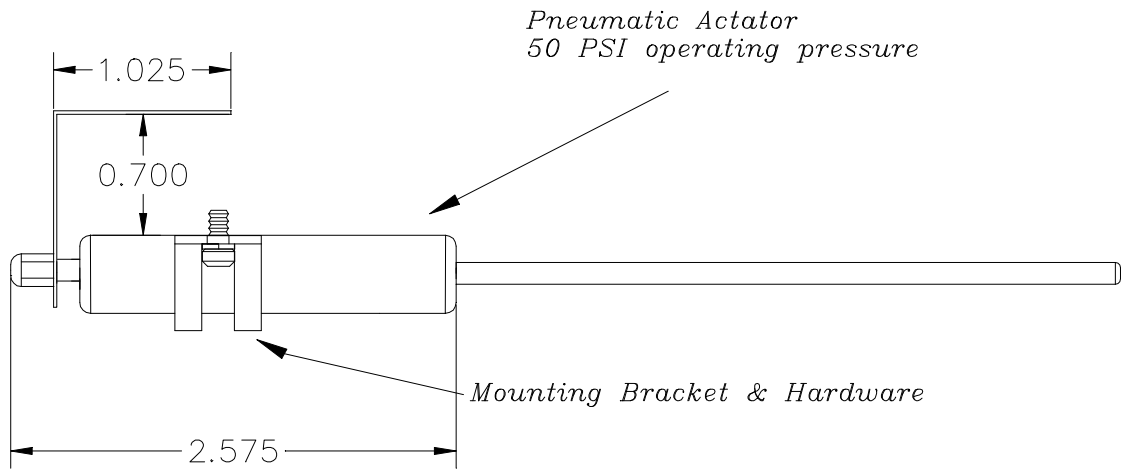

SINGLE BEND BAKEABLE SENSING HEAD  
501-034

REV. TAIA

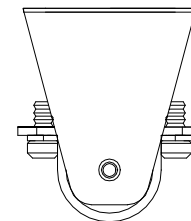
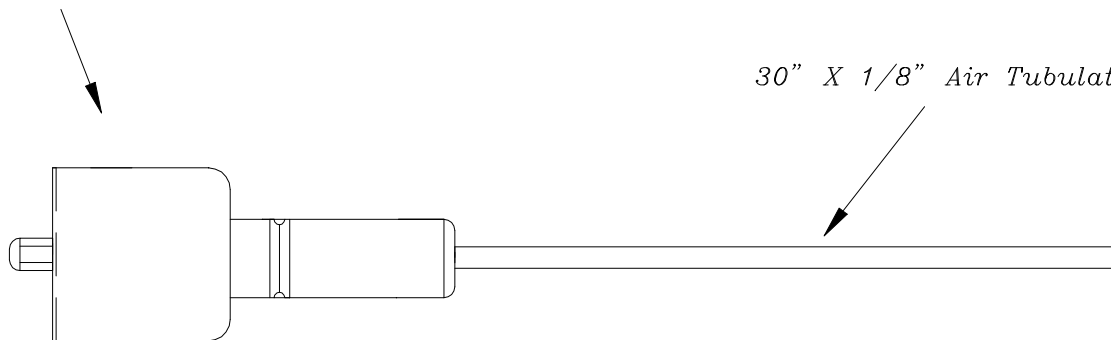

Shutter



|   |                |   |
|---|----------------|---|
| TOLERANCE<br>x.xx = ±0.01<br>x.xxx = ±0.005<br>ANGLES = ±1° |                | <br><b>SINGLE SHUTTER ASSEMBLY</b> |
| SCALE: NTS  | SIZE: A        |   |
| APPROVED BY: B.BRADY  | DATE: 04-18-94 | 501-048 <span style="float: right;">DOC. REV. A/A</span>  |



# **APPENDIX C**

*SHMX-4 Users Guide*





## SHMX-4 Operation

### Introduction

The Sensor Head Multiplexer (SHMX-4) used with a custom software version of the STM-100/MF Thin Film Thickness/Rate Monitor allows the individual monitoring of film thickness and deposition rates occurring upon up to four crystal sensing heads. The SHMX-4 allows the signals from 1 of 4 active sensors to be displayed on the controlling STM-100. This combination of the STM-100/MF and the SHMX-4 is useful in many multi-sensor monitoring applications. While only one of the four sensors can be actively measuring the rate and thickness, the accumulated thickness on each of these sensors can be calculated and displayed as the sensors are selected during a deposition process. This is because the initial frequency of the sensing crystal along with its film parameters are stored for each sensor. The custom version software for the STM-100 which accompanies this multiplexer provides the method and means for storing these initial conditions for each sensing crystal. This allows the user to switch between sensing crystals and display the correct thickness reading for each sensor along with the current deposition rate occurring at the selected sensor.

The front panel of the SHMX-4 is shown below, LED's indicate the active sensor. During operation a Crystal fail condition in the sensors will be indicated by a flashing LED.

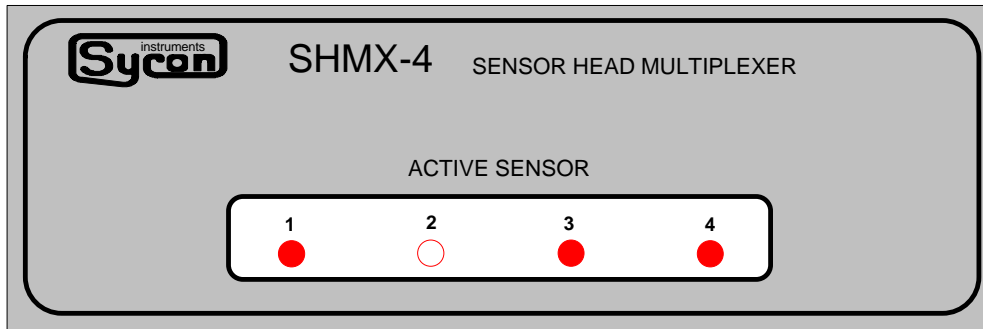

Figure C.1: SHMX-4 Front Panel

Special firmware is required in the controlling STM-100, and the two relay outputs

1. Elapsed Timer
2. Thickness Setpoint

have been disabled to allow access to the 4, individual sensors. The firmware version of the controlling STM-100 must be STM100 VI 6 or above. The version can be verified by inspecting the label on the ROM Chip on the printed circuit board.

## Operation

To access the individual sensors use the multiple film capability of the STM-100 / MF. Selecting film 1 from the front panel, or by external computer control, will select sensor 1. By selecting different films the active sensor will change according to the following table.

| Films   | Sensor |
|---------|--------|
| 1, 5, 9 | 1      |
| 2, 6    | 2      |
| 3, 7    | 3      |
| 4, 8    | 4      |

## Installation

Sensor and Controller connections to the SHMX-4 are made on the back panel, shown below.

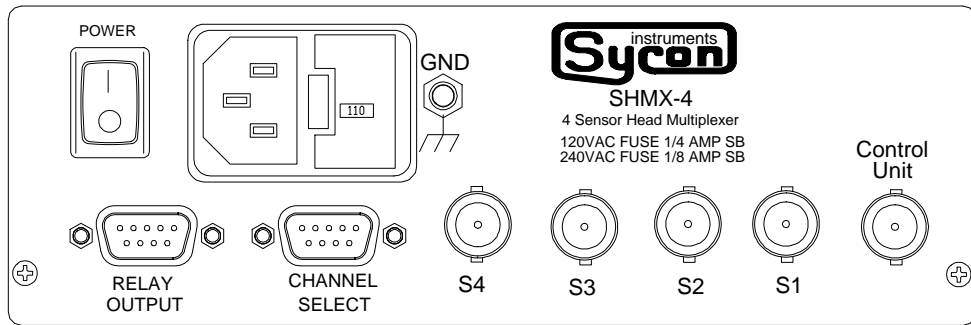

Figure C.2: SHMX-4 Back Panel

The BNC connectors labeled S1 through S4 are the individual Crystal sensor connections. The connection to the controlling STM-100 is made via 2 connection cables. The first is the control cable which goes between the Channel Select 9 Pin D connector on the SHMX-4 to the Input / Output 15 Pin D connector on the STM-100. The control cable is shown below. The Sensor BNC on the STM-100 and the SHMX's Control Unit BNC are connected.

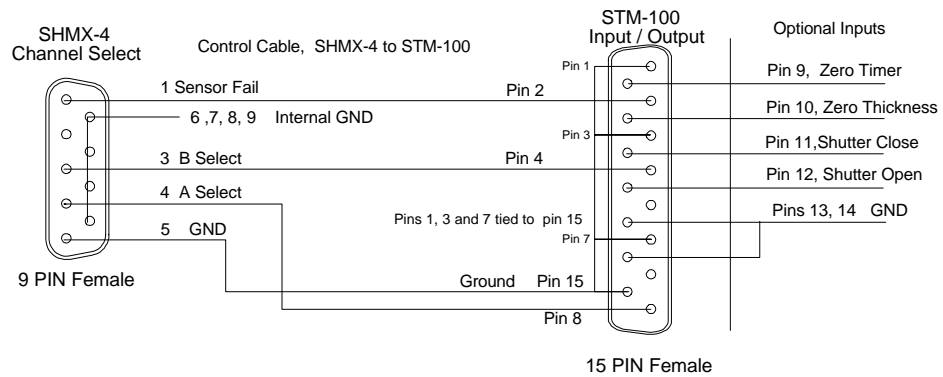

Figure C.3: SHMX-4 to STM-100 Control Cable

The Optional inputs for opening and closing the shutter and zeroing the timer and thickness can still be accessed by rewiring the 15 pin connector.

**SHMX-4 Relay Output** 9 pin D male.

| <b>Function</b> | <b>Pins</b> |
|-----------------|-------------|
| Sensor 1 Active | 1 and 2     |
| Sensor 2 Active | 3 and 4     |
| Sensor 3 Active | 5 and 6     |
| Sensor 4 Active | 7 and 8     |
| GND             | 9           |

The Relay Output Connection provides external active channel indication. The connector pins map as follows. The corresponding relays will open and close when the active sensor is changed.

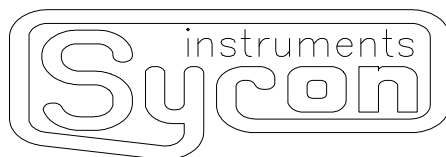

Sycon Instruments  
6757 Kinne Street  
East Syracuse, New York 13057-1215

Tel (315) 463-5297 Fax (315) 463-5298

---